



TOWN OF WEATHERSFIELD
SELECTBOARD

REGULAR MEETING AGENDA

TUESDAY, JULY 05, 2022 AT 6:30PM
MARTIN MEMORIAL HALL
5259 US ROUTE 5, ASCUTNEY, VT 05030

PHONE
(802) 674-2626

FAX
(802) 674-2117

-
1. Call to Order
 2. Pledge of Allegiance
 3. Agenda Review
 4. Comments from the Citizens on topics not on the agenda
 5. Review minutes from previous meeting: 06-16-2022; 06-20-2022
 6. Town Manager Announcements / Updates
 7. Vote to Award Compactor Bid
 8. Entertainment Request – October 8, 2022
 9. High Priority Building Improvements - ARPA
 10. Business Personal Property Tax
 11. Proposed future agenda items
 12. Appointments
 - a. Budget Committee (2 Vacancies)
 - b. Constable (1 Vacancy)
 - c. Energy Coordinator (1 Vacancy)
 - d. Parks & Recreation Commission (2 Vacancies)
 - e. Zoning Board of Adjustment - (1 Vacancy)
 13. Approve Warrant
 14. Any other business
 15. Adjourn

POSTED ON 06/30/2022

*ZOOM MEETING AVAILABLE
CLICK THE BRIDGE ON WEBSITE HOMEPAGE OR
PHONE NUMBER: (929) 205 - 6099 | MEETING ID: 542-595-4364 | NO PARTICIPANT ID:
PRESS # MEETING PASSCODE: 8021*

Select Board Meeting
Zoom Meeting
DRAFT of Special Select Board Meeting Minutes
Wednesday, June 16, 2022 6:30 PM

Select Board Members Present:
Paul Tillman
Kelly O'Brien
Michael Todd
Wendy Smith
David Fuller
Brandon Gulnick, Town Manager

- 1.) Call to Order by Michael Todd, Selectman at 6:30 pm
- 2.) Pledge of Allegiance was led by Paul Tillman.
- 3.) YTD Financials/Year End Projections/Fund Balance

RE: YTD Financials/ Year-End Projections/ Fund Balance/ Reserve Balances

YTD FINANCIALS

As of June 12, 2022, the General Fund has received 96% of revenues OR 1,386,190, and expenditures have reached 97% OR 1,396,674. The Highway Department has received 97% of revenues OR 1,123,980 and expenditures have reached 82% OR 941,017. The Solid Waste Department has received 107% of revenues OR 309,012 and expenditures have reached 96% OR 278,103.

GF Revenues Per Department-June 12, 2022

<i>Department</i>	<i>Budget</i>	<i>YTD</i>	<i>Remaining</i>	<i>%</i>
<i>GF Tax Revenue</i>	1,042,451	1,042,303	(148)	100%
<i>Administration</i>	300,550	228,349	(72,201)	76%
<i>Finance</i>	-	14,769	14,769	
<i>Library</i>	1,550	23	(1,527)	1%
<i>Town Clerk</i>	38,260	44,769	6,509	117%
<i>Listers Land</i>	19,000	15,780	(3,221)	83%
<i>Use</i>	5,750	8,478	2,728	147%
<i>Police Department</i>	16,000	25,719	9,719	161%
<i>Fire Services</i>	16,662	6,000	(10,662)	36%
<i>Total</i>	1,440,223	1,386,190	(54,033)	96%

GF Expenses Per Department -June 12, 2022

<i>Department</i>	Budget	YTD	Remaining	%
<i>Administration</i>	459,357	475,695	(16,339)	104%
<i>Library Finance</i>	125,614	108,484	17,129	86%
<i>Town Clerk</i>	74,902	84,317	(9,415)	113%
<i>Listers</i>	112,229	111,897	332	100%
<i>Land Use</i>	74,497	55,179	19,319	74%
<i>Police Department</i>	61,339	32,288	29,051	53%
<i>Fire Services</i>	320,942	329,426	(8,484)	103%
<i>Total</i>	211,344	199,387	11,957	94%
	1,440,223	1,396,674	43,549	97%

YEAR-END PROJECTIONS

At year-end on June 30, 2022, the General Fund is estimated to receive 98% of revenues OR 1,415,107 and expenditures are estimated to reach 101% OR 1,451,348. The Highway Fund is estimated to receive 102% of revenues OR 1,176,281 and expenditures are estimated to reach 91% OR 1,048,366. The Solid Waste District is estimated to receive 112% of revenues OR 323,012 and expenditures are estimated to reach 102% OR 293,508.

Projected Year End: General Fund= -36,240; Highway= 127,915; Solid Waste= 29,504

FUND BALANCE

The cumulative audited General Fund Balance was \$274,490, of which \$69,400 was a restatement from an allowance for doubtful accounts that was dissolved. During the development of the FY23 General Fund Budget, we used \$45,418 from the \$69,400 to reduce the property tax need in the General Fund. There is \$23,982 remaining to be allocated from the dissolution of the allowance for doubtful accounts and \$205,090 in cumulative fund balance. The total "fund balance" remaining is \$229,072.

The FY22 GF is estimated to close the year with a -\$36,240 +/- NET. Following final year-end balances, the remaining Fund Balance will be \$192,832 +/- in the General Fund. The cumulative audited Highway Fund Balance was \$81,036. During the development of the FY23 Highway Fund Budget, we used \$76,726 to reduce the property tax need in the Highway Fund. The Highway Fund is projected to end the year with a fund balance of \$127,915 The Solid Waste Fund has a cumulative deficit Fund Balance of -\$32,915.

4.) Tax Rate Discussion

RE: FY23 Tax Rate Discussion

64
65
66
67
68
69
70
71
72
73
74
75

Our Assessor has released the 4/ 11 as of 5/25/22 (Attachment A). The CU exemptions are not finished, and he is working on obtaining information relating to Solar to determine their values.

In FY21 the Grand List was \$3,316,189. In FY22 the Grand List was \$3,327,353.29. The FY23 “Draft Grant List” this year is \$3,315,906.95.

The Local Education Rate cannot be calculated until we receive the education tax rate (e.g., the additional 30K on Veterans Exemptions). For the purpose of obtaining a draft municipal tax rate the same Local Education Rate was used from FY22.

FY22 Town of Weathersfield Homestead Tax Rates totaling 2.5489 and Tax Amount on \$280,000 assessed value home

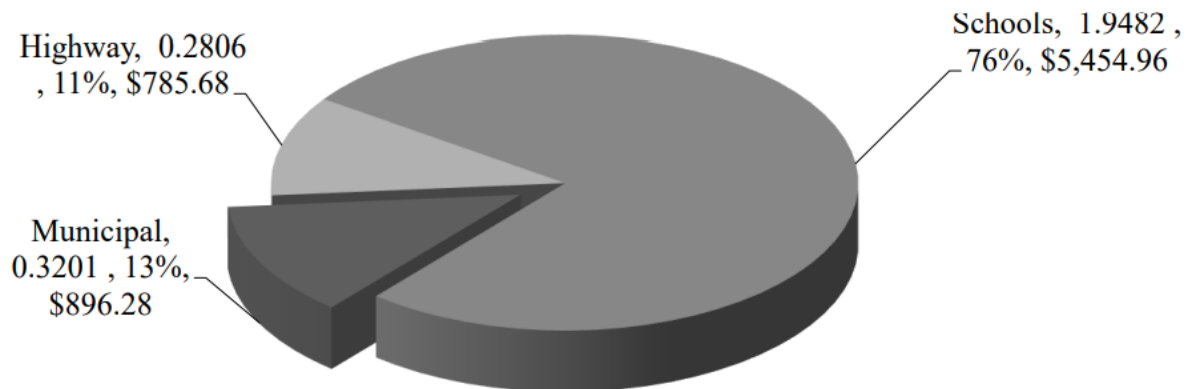

Taxes on average home = \$7,136.92

76
77
78
79
80
81
82
83
84
85
86
87
88
89
90
91

5.) Solid Waste Assessment Fee Discussion

6.) Proposed Future Agenda Items

Continued review and monitoring of the budget.

7.) Any Other Business

None

8.) Adjourn

92 Paul Tillman
93 Wendy Smith
94 No Discussion
95 Vote - Unanimous

96
97
98
99 Respectfully,
100 Chauncie Tillman
101 Alt. Recording Secretary

DRAFT

WEATHERSFIELD SELECTBOARD

David Fuller, Vice-Chairperson

Kelly O'Brien, Clerk

Wendy Smith, Selector

Paul Tillman, Selector

Michael Todd, Chairperson

1 Select Board Meeting
2 Zoom Meeting
3 DRAFT of Special Select Board Meeting Minutes
4 Wednesday, June 20, 2022 6:30 PM
5

6 Select Board Members Present:

7 Paul Tillman
8 Kelly O'Brien
9 Michael Todd
10 Wendy Smith
11 David Fuller
12 Brandon Gulnick, Town Manager
13

14 Attendees: John & Patti Arrison, Maureen R., Ginger Winberg, Jonah Blum, Beth Gorton, Ken
15 Blum, Roxane Blake, Marilyn Nichols, Ross Edwards, Robin Dawson, Steve Akenhead, Mandy
16 & Greg Martel, Rika Henderson, Evelyn & Tom Leach, David & Mary Gulbarnsen, Tina and
17 Willis Wood, Lisa Mair, Ken Poland, David Ainley, Marina Garland, George Ainley, Craig
18 Jewett, Julie Levy, Stephanie & David Lynch, deForest Bearse, Annemarie Christiansen
19

20 Online Attendees: Ryan Gumbart, Land Use Administrator, Joseph Bublat, Edward Gibbs, Nat
21 Stoddard, Mark, Anne Redmond, Brian Bosenbert, Beth Huton, Michael Dawson, Bart Mair
22

- 23 1.) Call to Order by Michael Todd, Selectman at 6:31 pm
- 24
- 25 2.) Pledge of Allegiance was led by Paul Tillman.
- 26
- 27 3.) Agenda Review – no changes
- 28
- 29 4.) Comments from Citizens not on the agenda
- 30

31 John Arrison said that several weeks ago he had sent a note to the Town Manager and to
32 the Chair with the recommendation that we ask all the departments to come up with
33 possible plans for fuel savings. He was curious if that had gone anywhere.
34

35 Brandon Gulnick said that they were definitely looking into fuel savings considering the
36 cost of fuel right now. It will take a bit for them to get that plan together, but the
37 conversation has been started.
38

- 39 5.) Review minutes from previous meetings: 6-6-2022;6-16-2022
40

41 There were no minutes for 6-16-22 available for this meeting. There were tabled until the
42 next Selectboard meeting on 7-5-22.
43

44 Paul Tillman made a motion to accept the meeting minutes from 6-6-22.

45 Wendy Smith – 2nd

46 No Discussion

47 Vote - unanimous
48
49

50 6.) Public Hearing: Adoption of Bylaw Amendments and Zoning Map
51

52 Michael Todd said that although this agenda said “Public Hearing” this is not a public
53 hearing. The public hearing is over and was closed at the last Selectboard meeting.
54

55 Michael Todd made a motion to adopt the bylaws as presented by the Planning
56 Commission.
57 2nd by David Fuller. That motion was tabled, making it the first item of business on this
58 agenda.
59

60 Michael Todd explained that a quasi-judicial process in State law allows a board to go
61 into deliberative session. The Zoning Board does it all the time. The Selectboard is
62 allowing you to observe a deliberative session. You are not allowed to participate, you
63 are not allowed to ask questions, you are not allowed to comment in any way.
64

65 After the deliberative session it was determined that there were still a lot of questions
66 regarding the land use map. It was decided to send the bylaws and the land use map back
67 to the Planning Commission for further review and adjustments.
68

69 7.) FY23 Tax Rate Discussion
70

71 Nate Stoddard attended the meeting via Zoom and said that there were recent changes.
72 About 3 weeks ago, the District Advisor at PB & R assigned to the Town of
73 Weathersfield, reached out to Barb and Nate and wanted to know where they were at.
74 They showed by way of applications, 6 solar projects within the Town that could need to
75 be addressed and have a value put on it.
76

77 Barb tracked down the owner of these sites, sent out the forms and last week they
78 received one back and sent it back to the district advisor. The district advisor put it
79 through their solar utility evaluation tool that is used State wide and came back with a
80 value on that property. Barb and Nate created a parcel and put a value on that parcel
81 based on that information.
82

83 The number Brandon is referring to that was given last week has changed. Your total
84 municipal grand list number was \$3,315,906.95 and now with the change with that one
85 parcel the new number is \$3,318,936. So, it went back up a little.
86

87 The biggest question is why did it go down from last year. Nate said the biggest reduction
88 came from the VT Transco property also known to some as Velco. It is a utility company
89 that saw almost a \$3.4 million dollar decrease in its evaluation. That comes from the
90 utility providing information to the State and the State putting it into their utility
91 evaluation tool.
92

93 Michael Todd wanted to know if there was a notification that they Town could receive
94 that this was happening and if there was any communication that this was happening.
95 Nate said he could look at the exact letter that the Town received on all of the utilities and
96 the dates they were received by the Town. It happens around the April 1st time frame.
97

98 David Fuller asked Nate if he had anything to do with plugging in the numbers or
99 anything for Velco. Nate said he did not, this is all State generated. Dave asked if it was
100 the facility and not the Weathersfield Personal Property Tax? Nate said that is correct, it
101 has nothing to do with the Personal Property Tax. It is a Utility tax generated by the
102 State. Dave also wanted to know if this could become a trend if we could see if go down
103 again in another year or two. Nate said the biggest reason it's gone down so much is
104 because the CLA was applied to the value.
105

106 The Grand List is completed as of today.
107

108 Michael Todd asked Nate to explain what causes the CLA to rise and fall. Nate said the
109 CLA is the calculation between your total sales for a 3-year time period that the State
110 does a study on divided by your assessed values.
111

112 The Selectboard is not able to set a tax rate tonight. They will need a new school rate and
113 Brandon is hoping to have this at the first meeting in July.
114

115 RE: FY23 Tax Rate Discussion (Prior to the change with the additional parcel)

116 Following the receipt of our homestead and non-homestead rates, a similar set of graphs
117 will be provided to the Town. The General Fund rate as shown in the graph below
118 includes county & local education. For the purpose of this meeting, we are distributing
119 the following graphs for FY22 (current fiscal year):
120
121

**FY22 Town of Weathersfield Homestead Tax Rates totaling
2.5489 and Tax Amount on \$280,000 assessed value home**

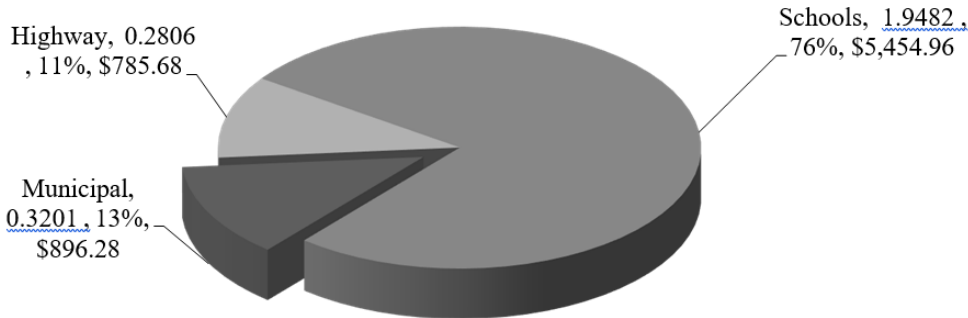

Taxes on average home = \$7,136.92

123 Our Assessor has released the 4/11 as of 5/25/22 (Attachment A). The CU
124 exemptions are not finished, and he is working on obtaining information relating to
125 Solar to determine their values.

126
127 In FY21 the Grand List was \$3,316,189. In FY22 the Grand List was \$3,327,353.29.
128 The FY23 “Draft Grant List” this year is \$3,315,906.95.

129
130 The Local Education Rate cannot be calculated until we receive the education tax
131 rate (e.g., the additional 30K on Veterans Exemptions). For the purpose of obtaining
132 a draft municipal tax rate the same Local Education Rate was used from FY22.
133

Total Draft FY23 Municipal Tax Rate				
Total Taxes to be Raised	Budget	FY23	FY22	Change
General Fund	1,049,016	0.3164	0.3054	0.0110
County Tax	26,433	0.0080	0.0079	0.0001
GF Special Articles	18,033	0.0054	0.0000	0.0054
Highway Fund	930,341	0.2806	0.2845	-0.0039
Highway-Separate Article	33,000	0.0100	0.0000	0.0100
Local Education	22,665	0.0068	0.0068	0.0000
Total Municipal Taxes to be Raised	2,079,488	0.6272	0.6046	0.0226

134
135
136
137 Proposed Quarterly Tax Payment Due Dates

138 August 17, 2022
139 November 16, 2022
140 February 15, 2023
141 May 17, 2023
142

143 **The Tax Rate will need to be set no later than the first meeting in July. Following this**
144 **meeting, we will send the bills to Doolittle’s to print/mail. Last year, the Selectboard**
145 **set the tax rate on July 13, 2021.**
146

FY23 General Fund Expenditures

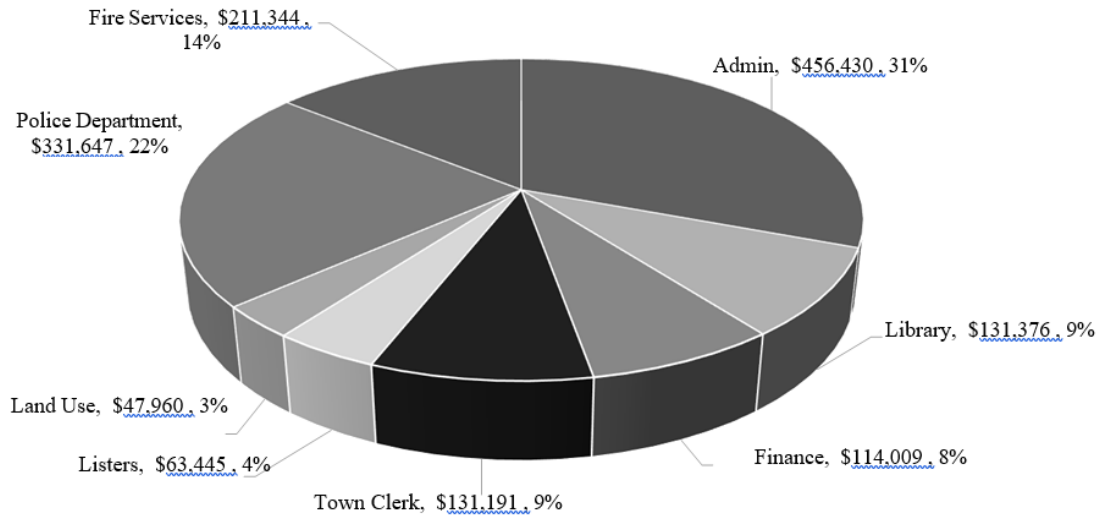

147
148

Admin includes personnel, water district, office, utilities, legal fees, insurance (auto, property, boiler, etc.), tax collection, county taxes, contracted services, ambulance, custodian, parks, 1879 schoolhouse, and appropriations.

152
153
154

8.) Perkinsville & Ascutney Wastewater Feasibility Study

155 Dear Board Members,
156

157 We held a meeting with Tom Brown, ANR/Water Supply Division. Mr. Brown
158 explained there is funding to complete a Wastewater Feasibility Study in the
159 form of a 100% forgivable loan. The first step is to secure an engineer to do the
160 project. We advertised an RFQ and received four (4) responses. A meeting was
161 held with Regional Planning to open the responses and rank them based on
162 criteria. We contacted Tom Brown to ask whether he has worked with our #1
163 choice. Mr. Brown stated that he is familiar with Otter Creek and has worked on
164 projects with them/approves of our selection.

165
166 See Attachment A – Agreement
167 See Attachment B - Application

168
169 Otter Creek Engineering will be present at the 6/20 meeting to answer questions.

170
171 Craig Jewett was present from Otter Creek Engineering to present the Wastewater Feasibility
172 Study. This is a State ARPA run program. These are loans, but forgivable loans. After the
173 selection process, Otter Creek provided the Town with a scope of services, associated budget and
174 agreement for the Town to consider and to be included as part of the loan application that gets
175 submitted to the funding program.

176

177 Because this goes through a loan process, this will go through an underwriting process and be
178 processed like a loan. This is a reimbursement process. You will have to pay for services and
179 then be reimbursed. However, because this is done through the ARPA process you will get a
180 determination on your subsidy before you sign before you move forward with your consultant.

181
182 Michael Todd asked about the anticipated turn around since we have to have the funds up front
183 and then get reimbursed. Brandon said that he is not sure about the anticipated turn around.
184 Craig Jewett said anticipated time from is probably 3-4 months, reimbursement time is around 2
185 weeks, however, wherever the money comes from up front is up to the Town.

186
187 9.) Letter to AOT: Request for Traffic Engineering Study – Route 131
188

189 Dear Ian Degutis,

190
191 We are requesting that AOT Traffic Operations conduct a review of the
192 speed limit on 131 in Weathersfield between Thrasher Road &
193 Weathersfield Center Road. Residents located at 2291 Route 131 have a
194 blind driveway and feel unsafe entering and exiting their property. There
195 have been several accidents on Route 131 near this location. We are
196 requesting that AOT Traffic Operations conduct a traffic engineering
197 study, as required by State Law, and forward a recommendation to the
198 Vermont Traffic Committee for a decision. The speed limit is 40MPH on
199 Route 131 in the vicinity of Victory Drive and Lavigne Road. Changing
200 the speed limit between Guld Rd and Thrasher Rd on Route 131 is our
201 recommendation.

202
203 If you have any questions or concerns, please do not hesitate to contact me.

204
205 Brandon is going to get together with Ray Stapleton to identify all areas that need to be
206 included and send one letter.

207
208 10.) Town Manager Announcements/Updates – tabled for the next Selectboard
209 Meeting

210
211 11.) High Priority Building Improvements - ARPA - tabled for the next Selectboard
212 Meeting

213
214 12.) Business Personal Property Tax - tabled for the next Selectboard meeting

215
216 13.) Proposed Future Agenda Items

- 217
218 • Town Manager Announcements/Updates – tabled for the next Selectboard
219 meeting
220 • High Priority Building Improvements - ARPA - tabled for the next Selectboard
221 meeting
222 • Business Personal Property Tax - tabled for the next Selectboard meeting

- 223
 224 14.) Appointments – tabled for the next Selectboard meeting
 225 a.) Budget Committee (2 Vacancies)
 226 b.) Constable (1 Vacancy)
 227 c.) Energy Coordinator (1 Vacancy)
 228 d.) Parks & Recreation Commission (2 Vacancies)
 229 e.) Zoning Board of Adjustment - (1 Vacancy)

230
 231 15.) Approve Warrant
 232
 233 Kelly O’Brien made a motion to approve the warrants of 6-20-22 as follows:

234	General Funds	Operating Expenses \$65,585.01
235		Payroll \$15,841.12
236		
237	Highway Fund	Operating Expenses \$8,877.48
238		Payroll \$7,993.53
239		
240	Solid Waste Management Fund	Operating Expenses \$ 21,536.60
241		Payroll \$1,733.11
242		
243	Library	Operating Expenses \$0.00
244		Payroll \$1,991.08
245		
246	Grants	Operating Expense \$700
247		
248	Dump Truck	\$75,508.60
249		
250	Grand Totals	Operating Expenses \$172,407.69
251		Payroll \$27,558.84
252		

253
 254 Paul Tillman – 2nd
 255 Vote - unanimous
 256

- 257 16.) Adjourn
 258
 259 Paul Tillman
 260 Wendy Smith – 2nd
 261 No Discussion
 262 Vote - Unanimous
 263
 264
 265
 266

267 Respectfully,
268 Chauncie Tillman
269 Alt. Recording Secretary

DRAFT

WEATHERSFIELD SELECTBOARD

David Fuller, Vice-Chairperson

Kelly O'Brien, Clerk

Wendy Smith, Selector

Paul Tillman, Selector

Michael Todd, Chairperson



Town of Weathersfield

5259 US ROUTE 5 | P.O. BOX 550 | WEATHERSFIELD, VT 05030 | PHONE (802) 674-2626 | FAX (802) 674-2117

Brandon Gulnick
Town Manager

July 1, 2022

RE: Town Manager Update

1. Building & Grounds Maintenance Contract

We received 1 bid for the maintenance of Martin Memorial Hall, the Library, Ascutney Green, Old Meeting House & Memorial Grove, Perkinsville Green, Perkinsville School, and Hoisington Field. TJ Property Maintenance was awarded the contract effective July 1, 2022, to June 30, 2024.

2. RFB Paving Quarry Road

We advertised an RFB to pave Quarry Road on June 23rd. The RFB was advertised in the Valley News, Vermont Bid Website, Weathersfield Website, and VLCT classifieds. A pre-bid conference will be held on July 7th at 10am. The question period ends on July 14th and bids are due no later than July 21st at 11:30am. A public bid opening will take place at Martin Memorial Hall in the upstairs conference room. The results will be available for Selectboard review on August 1st.

3. RFB Paving Stoughton Pond Road

We advertised an RFB to pave Stoughton Pond Road on June 14th. The RFB was advertised in the Valley News, Vermont Bid Website, Weathersfield Website, and VLCT classifieds. A pre-bid conference was held on June 30th at 10am. The question period ends on July 7th. Bids are due no later than July 13th at 11:30am. A public bid opening will take place on July 14th at 1pm. The results will be available for Selectboard review on July 18th.

4. EMD Training

Our EMD recently completed the Vermont Local Emergency Management Director 8 Hour Course through the State of Vermont Department of Public Safety. He will be organizing an Emergency Management Meeting during the month of August.

5. Accountant Update

We are currently outsourcing finance, including bank reconciliations, to VLCT. I have received questions from Board members on whether we should continue outsourcing finance or if we should hire a part-time and/or full-time accountant. In FY23 we budgeted a revenue of \$22,943 from Windsor to share an accountant, however, that is no longer the case. This revenue will not be received. We budgeted \$56,650 to pay an accountant salary. After we subtract the \$22,943 from the budgeted accountant salary,

we have a remainder of \$33,707 to spend on an Accountant in FY23. We also budgeted \$12,014 for insurance benefits. The total budgeted amount we have to spend is \$45,721. Keep in mind that contracting with VLCT reduces this amount each month, depending on the amount of time required. We will be having more discussions throughout the month of July to develop a memo with our options to present to the Selectboard.

6. Tax Rate Update

The State of Vermont released the Homestead and Non-Homestead Tax Rates on Friday, July 1, 2022. We will be holding a special meeting on Thursday, July 7th at 6:30pm to set the tax rate.

7. 1879 Schoolhouse

The Historical Grant for the Belfry project has been submitted and accepted. The project went very well, and the bell is ringing again. We held a meeting with BJ Esty on June 30th to discuss the future of the building. The committee would like to see the building used for Community Use. There are a few small tasks to complete prior to receiving a full occupancy permit. We will need to add this item on the Selectboard Agenda to discuss the development of a Trustees of the 1879 Schoolhouse committee, similar to the Martin Memorial Hall Board of Trustees, and to determine what the best use of the building will be.



Town of Weathersfield

5259 US ROUTE 5 | P.O. BOX 550 | WEATHERSFIELD, VT 05030 | PHONE (802) 674-2626 | FAX (802) 674-2117

Brandon Gulnick
Town Manager

July 1, 2022

RE: Compactor Bid Opening

We advertised an RFP to replace the compactor at the Transfer Station. The bid opening took place on June 30th at 2pm. We received 2 bids (attached).

<i>Company</i>	Compactor	Installation	Concrete Pad	Total Cost	Completion Date
<i>Alva Waste</i>	\$30,855	\$4,500	\$24,000	\$59,355	9/15/22
<i>Atlantic Recycling</i>	\$29,010	\$3,500	No bid	\$32,510	10/8/22

Atlantic Recycling did not follow instruction. The RFP specifically requested a full bid, including the compactor, installation, and laying a new concrete pad. Atlantic Recycling did not submit a bid for the concrete pad.

Both companies recommend replacing the receiver box, which will cost between \$9,975 from Atlantic Recycling + \$975 for shipping and \$11,550 from Alva Waste.

The total project cost with a new receiver box is \$70,905.

Attachment A – Bid Opening Sheet

Attachment B – Alva Waste Bid

Attachment C – Atlantic Recycling Bid

If you have any questions or concerns, please do not hesitate to contact me.

Sincerely,

Brandon Gulnick
Town Manager
Weathersfield, VT

Attachment A
[Bid Opening Sheet]

Attachment B
[Alva Waste Bid]

TOWN OF WEATHERSFIELD
REQUEST FOR BIDS FOR
TRASH COMPACTOR, INSTALLATION, AND CONCRETE PAD

Bidders name, address, email address, and phone number:

Alva Waste Services
1000 Charlestown Rd
Springfield, VT 05156

802-291-4807

alvawaste@vermontel.com
List similar work bidder has successfully completed:

Compactor Replacements at Springfield transfer
Station. Compactor replacements at Springfield Hospital.

40yd Octagon Receiver Box \$ 11,550

Cost of Compactor \$ 30,855

Installation \$ 4,500

Cost of Concrete Pad Replacement \$ 24,000 -see back for info.

Total Cost of Project \$ 70,905

Certified date for completion of
the delivery and installation: September 10th, 2022

Technical specifications for proposed units is required.

The undersigned, having familiarized themselves with the conditions of project as set forth in the Request for Bids, hereby proposes to furnish all supervision, technical personnel, labor, materials, tools, appurtenances, equipment, and services required to perform the required project, all for the TOTAL COST of this bid.

Signature of bidder:  Date: 6/29/22

Name of bidder: Matthew D Priestley

RECEIVED

JUN 30 2022

*J.D. Ann Dango
Town Clerk*

Concrete pad to be ~~removed~~ ^{Cleaned} and pressure washed. New pad will be pinned to existing pad with an average of 10.5 inches of 5000 PSI concrete poured over existing pad. 12.5' by 14' pad holding compactor will be level and 22' by 68' concrete pad will have a 2 inch slope to shed water. Both pads will have a 24" rebar grid with 1/2" rebar and will be saw cut after pad is poured.

TOWN OF WEATHERSFIELD
REQUEST FOR BIDS FOR
TRASH COMPACTOR, INSTALLATION, AND CONCRETE PAD

Bidders name, address, email address, and phone number:

Ava Waste Services
1080 Charlestown Rd
Springfield, VT 05156

802-291-4807

alvawaste@vermontel.com
List similar work bidder has successfully completed:

Compactor Replacements at Springfield transfer Station. Compactor replacements at Springfield Hospital.

40yd Octagon Receiver Box \$ 11,550

Cost of Compactor \$ 30,855

Installation \$ 4,500

Cost of Concrete Pad Replacement \$ 24,000 -see back for info.

Total Cost of Project \$ 70,905

Certified date for completion of the delivery and installation: September 15th, 2022

Technical specifications for proposed units is required.

The undersigned, having familiarized themselves with the conditions of project as set forth in the Request for Bids, hereby proposes to furnish all supervision, technical personnel, labor, materials, tools, appurtenances, equipment, and services required to perform the required project, all for the TOTAL COST of this bid.

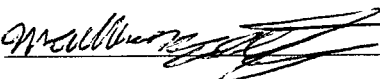
Signature of bidder:  Date: 6/29/22

Name of bidder: Matthew D Priestley

RECEIVED

APM
JUN 30 2022

*Ann Rango
Town Clerk*

Concrete pad to be ~~removed~~ ^{Cleaned} and pressure washed. New pad will be pinned to existing pad with an average of 10.5 inches of 5000 PSI concrete poured over existing pad. 12.5' by 14' pad holding compactor will be level and 22' by 68' concrete pad will have a 2 inch slope to shed water. Both pads will have a 24" rebar grid with 1/2" rebar and will be saw cut after pad is poured.

Attachment C
[Atlantic Recycling Bid]

Atlantic Recycling Equipment, LLC
Refuse Equipment Sales and Service
13 JESSIE DOE RD
ROLLINSFORD, NH 03869
Phone: 603-749-2414 Fax: 603-749-2421
WWW.ATLANTICRECYCLINGEQUIPMENT.COM

Quotation

Date 6/30/2022
 Quotation # 3188

Quotation Valid until: 7/30/2022

Prepared by: TMH

Submitted To:	
Weathersfield, VT Town of 5259 Route 5 PO Box 550 Ascutney, VT 05030 Edward Morris	
Notes	New 445HD Compactor

Project	
Transfer Station 5024 VT-106 Perkinsville, VT 05151 USA	
Terms	Net 30

Qty	Item	Description	Rate	Total
1	WQ445HD	Wastequip Model 445HD, 4yd. Stationary Compactor with the following standard specifications: Tri-Volt/TEFC Motor, UL/CUL Listed, WASTEC Rated, Multicycle Timer, 100% Full Light, ANSI Z.245.2 Compliant, Guardian Control System, NEMA 4 Rated Control Panel, Heavy Duty Ratchet Binders, Override-Packout Hydraulic Pressure Boost, (AMS) Automatic Maintenance Scheduler, Low Temperature oil, Pour point 20° F, Compactor Controls in the face of the cabinet standard. Compactor will be painted any standard color. Factory Warranty: Three (3) Year Structural, One (1) Year Parts and Labor.	23,975.00	23,975.00
1	Misc	15HP Remote Power unit, wired for 208 volt, three (3) phase power. Power unit will be remote, include Twenty (20') Foot hydraulic hoses, controls will be remote on a Forty (40') foot remote cord and the power unit will include ATF Oil in lieu of standard Hydraulic oil in the tank.	0.00	0.00
1	WQCO403	Oil heater thermostatically controlled, 10-60 gallon reservoir. Factory Installed.	0.00	0.00

Total

THESE PRICES DO NOT INCLUDE ANY APPLICABLE TAXES.

Payment Terms: 30 DAYS

Any alterations or deviations from the above specifications involving extra costs will be executed only upon written orders, and will become an extra charge to this quotation. All agreements are contingent upon strikes, accidents, or delays beyond our control. Owner to carry all necessary insurance coverage. Our employees are fully covered by workers compensation insurance.

PRICES ARE SUBJECT TO CHANGE WITHOUT NOTICE.

Acceptance:

The above quoted pricing, specifications and conditions are satisfactory and are hereby accepted. You are authorized to perform the job.

Authorized
Signature: _____

Date: _____

Please email signed quote to admin@arenh.com or fax to 603-749-2421

THANK YOU FOR YOUR BUSINESS!

RECEIVED
 2:10 PM
 JUN 30 2022
 TOWN CLERK
 Weathersfield, VT
 TOWN CLEAR

Atlantic Recycling Equipment, LLC
Refuse Equipment Sales and Service
13 JESSIE DOE RD
ROLLINSFORD, NH 03869
Phone: 603-749-2414 Fax: 603-749-2421
WWW.ATLANTICRECYCLINGEQUIPMENT.COM

Quotation

Date 6/30/2022
 Quotation # 3188

Quotation Valid until: 7/30/2022

Prepared by: TMH

Submitted To:	
Weathersfield, VT Town of 5259 Route 5 PO Box 550 Ascutney, VT 05030 Edward Morris	
Notes	New 445HD Compactor

Project	
Transfer Station 5024 VT-106 Perkinsville, VT 05151 USA	
Terms	Net 30

Qty	Item	Description	Rate	Total
1	WQCO166	Pressure gauge - color coded and numeric - on 40' hose-mounted. Atlantic Installed	0.00	0.00
1	WQCO122	Controls on 40' remote pendent in lieu of mounting in panel face, Factory option for Stationary & Self-Contained Models. Factory Installed.	0.00	0.00
1	WQCO201	Guide Rails - 5' standard, available on 145-245-265X & 345. Atlantic supplied.	0.00	0.00
1	FABRICATION	Two (2) Door Dog house fabricated and installed onto the compactor, both doors will include Magnetic Interlock switches to meet ANSI & OSHA Safety Regulations. Painted to match the compactor.	3,250.00	3,250.00
1	Freight	Freight charges to Weathersfield, VT Transfer Station.	1,280.00	1,280.00
1	Installations	Installation of the new compactor system into location, wired the power unit to the customer installed 100amp Electrical Disconnect, controls and pressure gauge installed and demo the operation of the new compactor to Town operators.	3,500.00	3,500.00
1	Fuel Surcharge	Round Trip Fuel Surcharge. 260 miles round trip mileage.	105.00	105.00
1	Overnight	Overnight charge for Two (2) Man crew	400.00	400.00

THESE PRICES DO NOT INCLUDE ANY APPLICABLE TAXES.

Total

Payment Terms: 30 DAYS

Any alterations or deviations from the above specifications involving extra costs will be executed only upon written orders, and will become an extra charge to this quotation. All agreements are contingent upon strikes, accidents, or delays beyond our control. Owner to carry all necessary insurance coverage. Our employees are fully covered by workers compensation insurance.

PRICES ARE SUBJECT TO CHANGE WITHOUT NOTICE.

Acceptance:

The above quoted pricing, specifications and conditions are satisfactory and are hereby accepted. You are authorized to perform the job.

Authorized
Signature: _____

Date: _____

Please email signed quote to admin@arenh.com or fax to 603-749-2421

THANK YOU FOR YOUR BUSINESS!

RECEIVED

2:10 PM
JUN 30 2022

WEATHERSFIELD, VT
TOWN CLERK

*Jo Ann Dango
Thank you*

Atlantic Recycling Equipment, LLC
Refuse Equipment Sales and Service
13 JESSIE DOE RD
ROLLINSFORD, NH 03869
Phone: 603-749-2414 Fax: 603-749-2421
WWW.ATLANTICRECYCLINGEQUIPMENT.COM

Quotation

Date 6/30/2022
 Quotation # 3188

Quotation Valid until: 7/30/2022

Prepared by: TMH

Submitted To:	
Weathersfield, VT Town of 5259 Route 5 PO Box 550 Ascutney, VT 05030 Edward Morris	
Notes	New 445HD Compactor

Project	
Transfer Station 5024 VT-106 Perkinsville, VT 05151 USA	
Terms	Net 30

Qty	Item	Description	Rate	Total
		Current Factory Lead time is 12 - 14 Weeks after receipt of this quote signed for approval and emailed back to my office. PLEASE SEE THE ATTACHED EXCEPTION SHEET. NOTE: Exception to the bid, Atlantic does not remove or install Concrete pads, The Town of Weathersfield, VT will be responsible to remove and install the new concrete pad prior to our arrival to complete the installation. Note: Exception to the Bid, The oil heater that will be installed is anew updated oil heater system and it will only be a 500 watt Oil heater.		
1	WQ40YDCTOCT	OPTIONAL: Wastequip 40yd Closed Top Stock Standard Octagon Style compaction container with the following specifications: 7gauge floor with 3" structural channels on 18" centerlines, 6" x 2" x 3/16" Main rails, Four (4) Wheels, 7 gauge lower walls, 10 gauge upper walls and 12 gauge roof section, Camlock style door latch, 4" x 3" x 1/8" Door tubing and frame of hole. Painted any standard color to match the compactor.	9,975.00	9,975.00

THESE PRICES DO NOT INCLUDE ANY APPLICABLE TAXES.

Total

Payment Terms: 30 DAYS

Any alterations or deviations from the above specifications involving extra costs will be executed only upon written orders, and will become an extra charge to this quotation. All agreements are contingent upon strikes, accidents, or delays beyond our control. Owner to carry all necessary insurance coverage. Our employees are fully covered by workers compensation insurance.

PRICES ARE SUBJECT TO CHANGE WITHOUT NOTICE.

Acceptance:

The above quoted pricing, specifications and conditions are satisfactory and are hereby accepted. You are authorized to perform the job.

Authorized
Signature: _____

Date: _____

Please email signed quote to admin@arenh.com or fax to 603-749-2421

THANK YOU FOR YOUR BUSINESS!

RECEIVED

2:10 PM
 JUN 30 2022

WEATHERSFIELD, VT
 TOWN CLERK

*John Am...
Town Clerk*

Atlantic Recycling Equipment, LLC
Refuse Equipment Sales and Service
13 JESSIE DOE RD
ROLLINSFORD, NH 03869
Phone: 603-749-2414 Fax: 603-749-2421
WWW.ATLANTICRECYCLINGEQUIPMENT.COM

Quotation

Date 6/30/2022
 Quotation # 3188

Quotation Valid until: 7/30/2022

Prepared by: TMH

Submitted To:	
Weathersfield, VT Town of 5259 Route 5 PO Box 550 Ascutney, VT 05030 Edward Morris	
Notes	New 445HD Compactor

Project	
Transfer Station 5024 VT-106 Perkinsville, VT 05151 USA	
Terms	Net 30

Qty	Item	Description	Rate	Total
1	Freight	Freight charges to Weathersfield, VT Transfer Station for the 40yd. Octagon container Only. The Town of Weathersfield, VT will be responsible to off load the Container from the trailer at the time of delivery.	975.00	975.00
Total				\$43,460.00

THESE PRICES DO NOT INCLUDE ANY APPLICABLE TAXES.

Payment Terms: 30 DAYS

Any alterations or deviations from the above specifications involving extra costs will be executed only upon written orders, and will become an extra charge to this quotation. All agreements are contingent upon strikes, accidents, or delays beyond our control. Owner to carry all necessary insurance coverage. Our employees are fully covered by workers compensation insurance.

PRICES ARE SUBJECT TO CHANGE WITHOUT NOTICE.

Acceptance:

The above quoted pricing, specifications and conditions are satisfactory and are hereby accepted. You are authorized to perform the job.

Authorized

Signature: _____

Date: _____

Please email signed quote to admin@arenh.com or fax to 603-749-2421

THANK YOU FOR YOUR BUSINESS!

RECEIVED

2:10 pm
 JUN 30 2022

WEATHERSFIELD, VT
 TOWN CLERK

*9:10 Am Done
 Town Clerk*



ATLANTIC RECYCLING EQUIPMENT

WE **A.R.E.** YOUR EQUIPMENT SPECIALISTS

June 30, 2022

Town of Weathersfield, VT
PO Box 550
5259 US Route 5
Ascutney, VT 05030

Attn: Brendon Gulnick – Town Manager

REF: “Exception to Bid Conditions and Specifications.

Execption 1: Atlantic does not remove or install Concrete pads, we are an Equipment dealer only. Atlantic has NOT included any pricing for the concrete pad required in the bid sepcs.

Exception 2: The manufacturer is NO longer using 2000watt oil heaters in the hydraulic tank, the new style oil heaters that are supplied today are extremely more efficient in energy, and they have less maintenance problems. They are Thermostatically controlled and pre-set for temperature. This compactor power unit will include a 500watt Oil heater in lieu of the 2000watt oil heater you have requested in your bid.

STATIONARY COMPACTORS

445HD & 445XHD

Wastequip's efficient, powerful, and long-lasting industrial 4-yard compactor has a large 65" x 60" clear top opening, and is ideal for dry waste and recycling material.



Guardian™ Control System

- New user-friendly controls
- Automatic Maintenance Tracking
- Superior 24-volt control
- NEMA 4 rated enclosure
- Remote power unit with weather protection cover

Heavy-Duty Ratchet Binders

- 1" thick hooks
- Greasable fittings

Performance

- 14" ram penetration minimizes spring-back of material
- Heavy-duty 8" x 8" x 1" breaker bar

Large-Access Openings for Maintenance and Service

- Removable rear panel
- Removable side panels



Easy-to-use 24-volt Guardian Control System (optional remote pendant shown)

** Use of an oil heater or extreme cold weather hydraulic oil is recommended in extreme cold conditions.*

 **WASTEQUIP®**

STATIONARY COMPACTORS

445HD & 445XHD

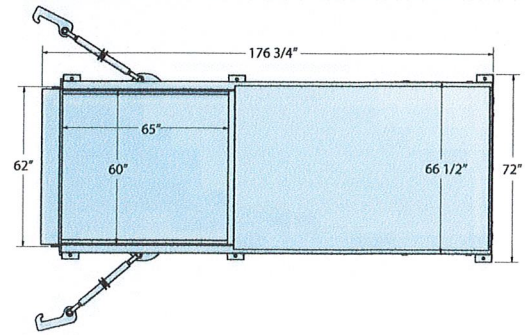
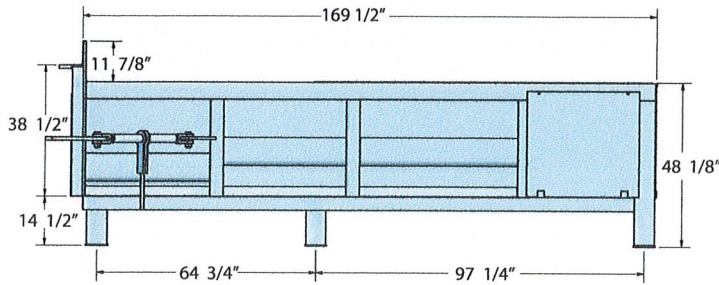

Standard Features

- 1/2" thick ram floor
- 57-second cycle time
- Controls in panel face
- Automatic Maintenance Tracking
- Full container light
- Low temperature oil
- Multi-cycle timer
- Operational and service manual
- NEMA 4 control panel protects against windblown dust, splashing water, and hose-directed water
- Primed and painted in multiple colors
- Remote power unit with weather cover

Options

- Advance warning light
- Color-coded pressure gauge
- Guide rails with/without stops
- Oil heater
- Photo electric eye
- Odor control system
- Cart dumper
- Biodegradable oil

Warranty

- 3-1-1 warranty (3-year structural, 1-year parts, 1-year labor)

Specifications

		445HD	445XHD*
Charge Box	Wastequip rating	4.00 cu. yds.	
	Wastec rating	2.59 cu. yds.	
	Clear top opening	65" Length x 60" Width	64" Length x 60" Width
	Compactor weight with power unit	6,700 lbs.	6,900 lbs.
Ram	Ram height	30.50"	
	Ram penetration	14.00"	
	Face plate	1/2" steel with 3/4" stiffener plates	
	Base plate	3/8" steel with 10 gauge formed stiffeners	
	Top plate	1/4" steel with 10 gauge formed stiffeners	
Compactor Head	Side plates	1/4" formed plate	
	Floor	1/2" steel with 10 gauge channels at 12" spacing	
	Sides	1/4" steel formed vertical stiffeners and formed horizontal stiffeners	1/4" steel formed vertical stiffeners and formed horizontal stiffeners; side stiffeners, gussets in discharge area
Electrical	Breaker bar	8" x 8", 1" angled steel	1" thick breaker bar plate
	Top deck	12 gauge steel (standard)	
	Electric motor, fan cooled	15 hp	
Hydraulic Performance	Voltage	208/230/460, 3 phase 60 Hz	
	Power box	UL rated, TEFC housing	
	Automated cycle operation	Push-button start extends, retracts & stops automatically	
	Pump	16.4 gpm	
	Pump type	Fixed gear	
	Hydraulic oil tank	25-gallon reservoir	
	Cylinder bore/rod/stroke	6.25" bore, 4.75" rod, 80" stroke	
	Normal ram face pressure	52,100 lbs.	64,400 lbs.
	Max. ram face pressure	56,500 lbs.	70,500 lbs.
	Normal ram psi	28.47 psi	35.19 psi
Maximum ram psi	31.80 psi	38.52 psi	
Cubic yards per hour	164		
Power unit location	Remote		
Cycle time	57 seconds		

* Specifications are the same as the 445HD, except where indicated.



Replacement parts available online at www.gotoparts.com.

Standard Color Choices

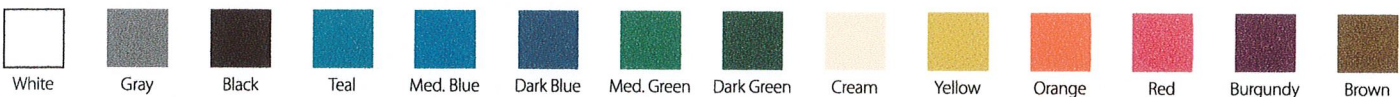

Colors shown are as accurate as printing allows. The actual color is subject to variation from the printed color sample. Color choices vary by plant location. Please contact your local sales representative for available colors. Custom colors are available upon request and are subject to an additional charge.



Tel: 877.468.9278 | sales@wastequip.com | www.wastequip.com

Wastequip is the leading North American manufacturer of waste and recycling equipment for collecting, processing, and transporting recyclables and solid or liquid waste. © Wastequip. All rights reserved. Specifications subject to improvement without notice. Equipment displayed should be operated by properly trained personnel. Operators should become familiar with OSHA, ANSI, and any other applicable standards or laws for using this equipment. Improper use, misuse, or lack of maintenance could cause injury to people and/or property. Photos used in the literature are illustrative only. We assume no liability or responsibility for proper training/operation of equipment not manufactured by Wastequip. We reserve the right to make changes at any time without notice. Information contained within this literature is intended to be the most accurate available at time of printing.

OCTAGON PACKER RECEIVER

Octagon Receivers are engineered to withstand the repeated pressures and abuse of compactors. Designed to provide **LONG-LASTING, DEPENDABLE** performance for high-volume refuse accounts.

Compatible with most major brand roll-off systems.

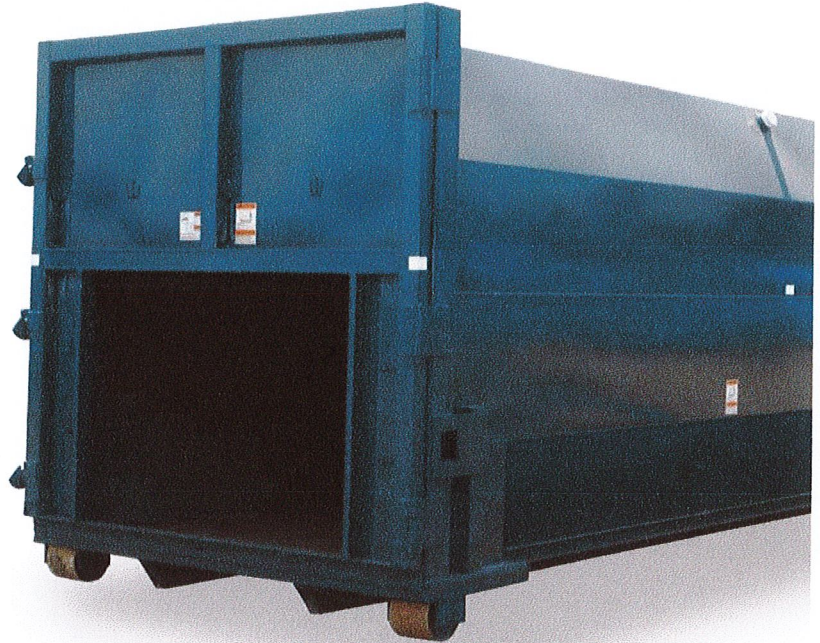

FEATURES & BENEFITS

- 7 gauge floor with 3" structural channels on 18" centers
- 7 gauge lower front and sides
- 10 gauge upper front and sides
- ANSI-compatible opening
- Painted any standard color
- Several sizes and hookup options available

877.468.9278
sales@wastequip.com
www.wastequip.com



OCTAGON PACKER RECEIVER

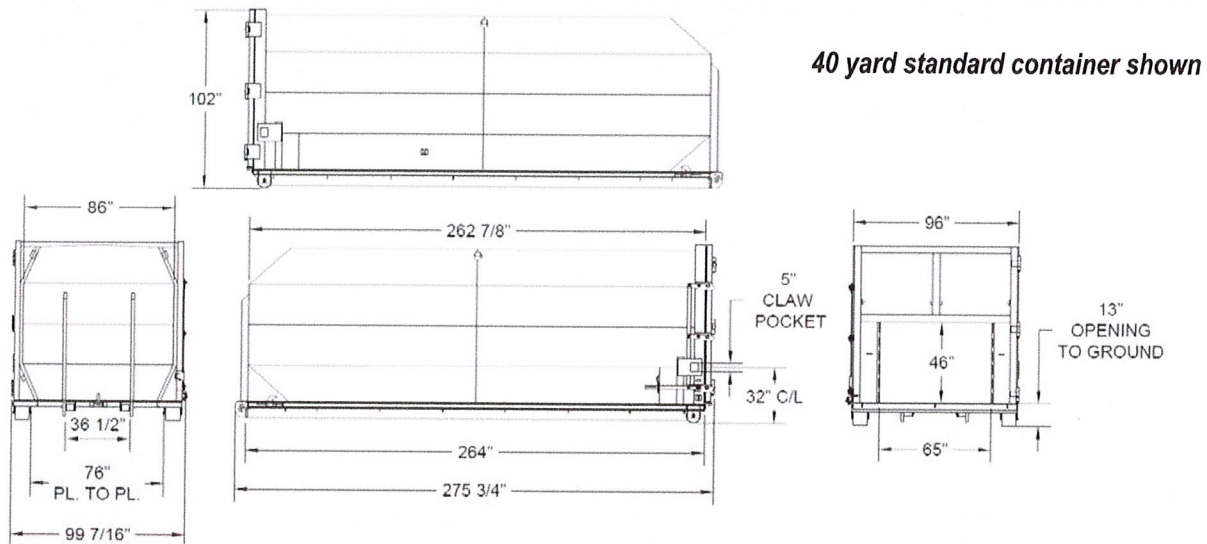

40 yard standard container shown

Outside Dimensions				Rated Capacity Cubic Yards	Approximate Shipping Weight
Description	Length	Width	Height		
20-Yard OCT	15'	100"	86"	20	4,600 lbs.
30-Yard OCT	17' 7"	100"	102"	30	5,500 lbs.
40-Yard OCT	23'	100"	102"	40	7,024 lbs.

Options
Front wheels
Belly bands
Crash Plate
Ratchet binder in place of standard latch
HD or XHD specs. available for larger compactors
Painted any standard color- special colors available upon request

Standard Specifications
Floor: 7 gauge with 3" structural channels on 18" centers and 6" x 2" x 3/16" structural tubing main rails
Front and Sides: 7 gauge lower front and sides and 10 gauge upper front and sides
Standard: 40 yard has maximum payload of 60,000 lbs. and a maximum force rate of 70,000 lbs. ANSI-compatible opening 13" to ground. 46" tall X 65" wide opening. Other sizes available.

Standard Color Choices*

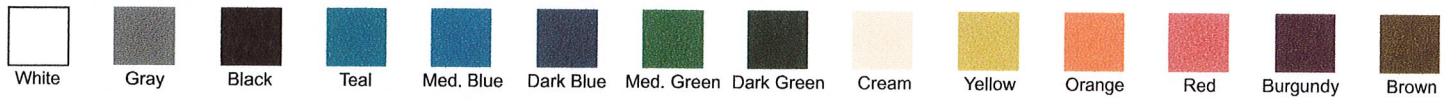

Colors shown are as accurate as printing allows. The actual color is subject to variation from the printed color sample. Color choices vary by plant location. Please contact your local sales representative for available colors. Custom colors are available upon request and are subject to an additional charge.



Tel: 877.468.9278 | sales@wastequip.com | www.wastequip.com

Wastequip is the leading North American manufacturer of waste and recycling equipment for collecting, processing and transporting recyclables and solid or liquid waste. © July 2015 Wastequip, all rights reserved. Specifications subject to improvement without notice. Equipment displayed should be operated by properly trained personnel. Operators should become familiar with OSHA, ANSI and any other applicable standards or laws for using this equipment. Improper use, misuse, or lack of maintenance could cause injury to people and/or property. Photos used in the literature are illustrative only. We assume no liability or responsibility for proper training/operation of equipment not manufactured by Wastequip. We reserve the right to make changes at any time without notice. Information contained within this literature is intended to be the most accurate available at time of printing.



ATLANTIC RECYCLING EQUIPMENT

WE **A.R.E.** YOUR EQUIPMENT SPECIALISTS

Installation References.

1. **Town of Gilmanton, NH** – Transfer Station – New 445HD Compactor and hopper system. – Contact: Heidi Duval – Town Administrator 603-267-6700
2. **Town of Cape Elizabeth, ME** – Five (5) New 445XHD Compactors w/ Dog Houses. Contact: Robert Malley – 207-799-4151
3. **Town of Rockingham, VT** – One (1) New 445XHD Compactor & Dog House. Contact: Shane O’Keefe – 802-463-3964 ext 1104
4. **Town of Epping, NH** – Three (3) – 445HD Compactors with hoppers & Dog Houses. Contact: David Rienhold – Mobile: 603-608-9488
5. **Town of Deerfield, NH** – Four (4) – 445HD Compactors with rear feed chute systems. Contact: Rick Pelletier – Mobile: 603-566-8985
6. **Town of Norwich, VT** – Two (2) – 445HD Compactors with Dog Houses. Contact: Andy Hodgkins – 802-649-2209
7. **Town of Freeport, ME** – One (1) – 445HD Compactor with Dog House. Contact: Sandy Duplissis – 207-865-3740

PO Box 609, Rollinsford, NH 03869
Phone: 800-370-7370 Fax: 603-749-2421
www.AtlanticRecyclingEquipment.com

TOWN OF WEATHERSFIELD
REQUEST FOR BIDS FOR
TRASH COMPACTOR, INSTALLATION, AND CONCRETE PAD

Bidders name, address, email address, and phone number:

ATLANTIC RECYCLING EQUIPMENT, LLC
13 JESSIE DOE ROAD
ROLLINSFORD, NH 03869-0609
TODD HAGEN, OWNER

List similar work bidder has successfully completed:

PLEASE SEE ATTACHED REFERENCE SHEET

Cost of Compactor

\$ 29,010.00

Installation

\$ 3,500.00

Cost of Concrete Pad Replacement

\$ NO BID

Total Cost of Project

\$ 32,510.00 w/o Container

Certified date for completion of
the delivery and installation:

FIRST WEEK OF OCTOBER 2022, VOLUNTARILY
WK OF 10/3/2022

Technical specifications for proposed units is required.

PLEASE SEE ATTACHED SPEC SHEETS

The undersigned, having familiarized themselves with the conditions of project as set forth in the Request for Bids, hereby proposes to furnish all supervision, technical personnel, labor, materials, tools, appurtenances, equipment, and services required to perform the required project, all for the TOTAL COST of this bid.

Signature of bidder:

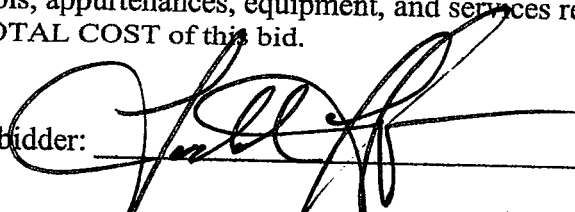

Date:

6/30/2022

Name of bidder:

TODD HAGEN, OWNER

Insurance Certificates 9 W-9 will be provided if we are Award
The Bid.

Atlantic Recycling Equipment, LLC

Refuse Equipment Sales and Service

13 JESSIE DOE RD

ROLLINSFORD, NH 03869

Phone: 603-749-2414 Fax: 603-749-2421

WWW.ATLANTICRECYCLINGEQUIPMENT.COM

Quotation

Date 6/30/2022

Quotation # 3188

Quotation Valid until: 7/30/2022

Prepared by: TMH

Submitted To:	
Weathersfield, VT Town of 5259 Route 5 PO Box 550 Ascutney, VT 05030 Edward Morris	
Notes	New 445HD Compactor

Project	
Transfer Station 5024 VT-106 Perkinsville, VT 05151 USA	
Terms	Net 30

Qty	Item	Description	Rate	Total
1	WQ445HD	Wastequip Model 445HD, 4yd. Stationary Compactor with the following standard specifications: Tri-Volt/TEFC Motor, UL/CUL Listed, WASTEC Rated, Multicycle Timer, 100% Full Light, ANSI Z.245.2 Compliant, Guardian Control System, NEMA 4 Rated Control Panel, Heavy Duty Ratchet Binders, Override-Packout Hydraulic Pressure Boost, (AMS) Automatic Maintenance Scheduler, Low Temperature oil, Pour point 20° F, Compactor Controls in the face of the cabinet standard. Compactor will be painted any standard color. Factory Warranty: Three (3) Year Structural, One (1) Year Parts and Labor.	23,975.00	23,975.00
1	Misc	15HP Remote Power unit, wired for 208 volt, three (3) phase power. Power unit will be remote, include Twenty (20') Foot hydraulic hoses, controls will be remote on a Forty (40') foot remote cord and the power unit will include ATF Oil in lieu of standard Hydraulic oil in the tank.	0.00	0.00
1	WQCO403	Oil heater thermostatically controlled, 10-60 gallon reservoir. Factory Installed.	0.00	0.00

THESE PRICES DO NOT INCLUDE ANY APPLICABLE TAXES.

Total

Payment Terms: 30 DAYS

Any alterations or deviations from the above specifications involving extra costs will be executed only upon written orders, and will become an extra charge to this quotation. All agreements are contingent upon strikes, accidents, or delays beyond our control. Owner to carry all necessary insurance coverage. Our employees are fully covered by workers compensation insurance.

PRICES ARE SUBJECT TO CHANGE WITHOUT NOTICE.

Acceptance:

The above quoted pricing, specifications and conditions are satisfactory and are hereby accepted. You are authorized to perform the job.

Authorized

Signature: _____

Date: _____

Please email signed quote to admin@arenh.com or fax to 603-749-2421

RECEIVED

2:10 PM
JUN 30 2022

*3:10 Am Done
TOWN CLERK*

THANK YOU FOR YOUR BUSINESS!

WEATHERSFIELD, VT
TOWN CLERK

Atlantic Recycling Equipment, LLC
Refuse Equipment Sales and Service
13 JESSIE DOE RD
ROLLINSFORD, NH 03869
Phone: 603-749-2414 Fax: 603-749-2421
WWW.ATLANTICRECYCLINGEQUIPMENT.COM

Quotation

Date 6/30/2022
 Quotation # 3188

Quotation Valid until: 7/30/2022

Prepared by: TMH

Submitted To:	
Weathersfield, VT Town of 5259 Route 5 PO Box 550 Ascutney, VT 05030 Edward Morris	
Notes	New 445HD Compactor

Project	
Transfer Station 5024 VT-106 Perkinsville, VT 05151 USA	
Terms	Net 30

Qty	Item	Description	Rate	Total
1	WQCO166	Pressure gauge - color coded and numeric - on 40' hose-mounted. Atlantic Installed	0.00	0.00
1	WQCO122	Controls on 40' remote pendent in lieu of mounting in panel face, Factory option for Stationary & Self-Contained Models. Factory Installed.	0.00	0.00
1	WQCO201	Guide Rails - 5' standard, available on 145-245-265X & 345. Atlantic supplied.	0.00	0.00
1	FABRICATION	Two (2) Door Dog house fabricated and installed onto the compactor, both doors will include Magnetic Interlock switches to meet ANSI & OSHA Safety Regulations. Painted to match the compactor.	3,250.00	3,250.00
1	Freight	Freight charges to Weathersfield, VT Transfer Station.	1,280.00	1,280.00
1	Installations	Installation of the new compactor system into location, wired the power unit to the customer installed 100amp Electrical Disconnect, controls and pressure gauge installed and demo the operation of the new compactor to Town operators.	3,500.00	3,500.00
1	Fuel Surcharge	Round Trip Fuel Surcharge. 260 miles round trip mileage.	105.00	105.00
1	Overnight	Overnight charge for Two (2) Man crew	400.00	400.00

THESE PRICES DO NOT INCLUDE ANY APPLICABLE TAXES.

Total

Payment Terms: 30 DAYS

Any alterations or deviations from the above specifications involving extra costs will be executed only upon written orders, and will become an extra charge to this quotation. All agreements are contingent upon strikes, accidents, or delays beyond our control. Owner to carry all necessary insurance coverage. Our employees are fully covered by workers compensation insurance.

PRICES ARE SUBJECT TO CHANGE WITHOUT NOTICE.

Acceptance:

The above quoted pricing, specifications and conditions are satisfactory and are hereby accepted. You are authorized to perform the job.

Authorized
Signature: _____

Date: _____

Please email signed quote to admin@arenh.com or fax to 603-749-2421

THANK YOU FOR YOUR BUSINESS!

RECEIVED

JUN 30 2022

WEATHERSFIELD, VT
TOWN CLERK

9:10 AM June 30 2022
TMH

Atlantic Recycling Equipment, LLC

Refuse Equipment Sales and Service

13 JESSIE DOE RD

ROLLINSFORD, NH 03869

Phone: 603-749-2414 Fax: 603-749-2421

WWW.ATLANTICRECYCLINGEQUIPMENT.COM

Quotation

Date 6/30/2022

Quotation # 3188

Quotation Valid until: 7/30/2022

Prepared by: TMH

Submitted To:	
Weathersfield, VT Town of 5259 Route 5 PO Box 550 Ascutney, VT 05030 Edward Morris	
Notes	New 445HD Compactor

Project	
Transfer Station 5024 VT-106 Perkinsville, VT 05151 USA	
Terms	Net 30

Qty	Item	Description	Rate	Total
1	WQ40YDCTOCT	<p>Current Factory Lead time is 12 - 14 Weeks after receipt of this quote signed for approval and emailed back to my office.</p> <p>PLEASE SEE THE ATTACHED EXCEPTION SHEET.</p> <p>NOTE: Exception to the bid, Atlantic does not remove or install Concrete pads, The Town of Weathersfield, VT will be responsible to remove and install the new concrete pad prior to our arrival to complete the installation.</p> <p>Note: Exception to the Bid, The oil heater that will be installed is anew updated oil heater system and it will only be a 500 watt Oil heater.</p> <p>OPTIONAL: Wastequip 40yd Closed Top Stock Standard Octagon Style compaction container with the following specifications: 7gauge floor with 3" structural channels on 18" centerlines, 6" x 2" x 3/16" Main rails, Four (4) Wheels, 7 gauge lower walls, 10 gauge upper walls and 12 gauge roof section, Camlock style door latch, 4" x 3" x 1/8" Door tubing and frame of hole. Painted any standard color to match the compactor.</p>	9,975.00	9,975.00

THESE PRICES DO NOT INCLUDE ANY APPLICABLE TAXES.

Total

Payment Terms: 30 DAYS

Any alterations or deviations from the above specifications involving extra costs will be executed only upon written orders, and will become an extra charge to this quotation. All agreements are contingent upon strikes, accidents, or delays beyond our control. Owner to carry all necessary insurance coverage. Our employees are fully covered by workers compensation insurance.

PRICES ARE SUBJECT TO CHANGE WITHOUT NOTICE.

Acceptance:

The above quoted pricing, specifications and conditions are satisfactory and are hereby accepted. You are authorized to perform the job.

Authorized

Signature: _____

Date: _____

Please email signed quote to admin@arenh.com or fax to 603-749-2421

THANK YOU FOR YOUR BUSINESS!

RECEIVED
JUN 30 2022
Flora Am...
Town Clerk
WEATHERSFIELD, VT
TOWN CLERK

Atlantic Recycling Equipment, LLC

Refuse Equipment Sales and Service

13 JESSIE DOE RD

ROLLINSFORD, NH 03869

Phone: 603-749-2414 Fax: 603-749-2421

WWW.ATLANTICRECYCLINGEQUIPMENT.COM

Quotation

Date 6/30/2022

Quotation # 3188

Quotation Valid until: 7/30/2022

Prepared by: TMH

Submitted To:	
Weathersfield, VT Town of 5259 Route 5 PO Box 550 Ascutney, VT 05030 Edward Morris	
Notes	New 445HD Compactor

Project	
Transfer Station 5024 VT-106 Perkinsville, VT 05151 USA	
Terms	Net 30

Qty	Item	Description	Rate	Total
1	Freight	Freight charges to Weathersfield, VT Transfer Station for the 40yd. Octagon container Only. The Town of Weathersfield, VT will be responsible to off load the Container from the trailer at the time of delivery.	975.00	975.00
Total				\$43,460.00

THESE PRICES DO NOT INCLUDE ANY APPLICABLE TAXES.

Payment Terms: 30 DAYS

Any alterations or deviations from the above specifications involving extra costs will be executed only upon written orders, and will become an extra charge to this quotation. All agreements are contingent upon strikes, accidents, or delays beyond our control. Owner to carry all necessary insurance coverage. Our employees are fully covered by workers compensation insurance.

PRICES ARE SUBJECT TO CHANGE WITHOUT NOTICE.

Acceptance:

The above quoted pricing, specifications and conditions are satisfactory and are hereby accepted. You are authorized to perform the job.

Authorized

Signature: _____

Date: _____

Please email signed quote to admin@arenh.com or fax to 603-749-2421

THANK YOU FOR YOUR BUSINESS!

RECEIVED

JUN 30 2022

WEATHERSFIELD, VT
TOWN CLERK

*3/10/2022
Town Clerk*



ATLANTIC RECYCLING EQUIPMENT

WE **A.R.E.** YOUR EQUIPMENT SPECIALISTS

June 30, 2022

Town of Weathersfield, VT
PO Box 550
5259 US Route 5
Ascutney, VT 05030

Attn: Brendon Gulnick – Town Manager

REF: “Exception to Bid Conditions and Specifications.

Exception 1: Atlantic does not remove or install Concrete pads, we are an Equipment dealer only. Atlantic has NOT included any pricing for the concrete pad required in the bid sepcs.

Exception 2: The manufacturer is NO longer using 2000watt oil heaters in the hydraulic tank, the new style oil heaters that are supplied today are extremely more efficient in energy, and they have less maintenance problems. They are Thermostatically controlled and pre-set for temperature. This compactor power unit will include a 500watt Oil heater in lieu of the 2000watt oil heater you have requested in your bid.

STATIONARY COMPACTORS

445HD & 445XHD

Wastequip's efficient, powerful, and long-lasting industrial 4-yard compactor has a large 65" x 60" clear top opening, and is ideal for dry waste and recycling material.

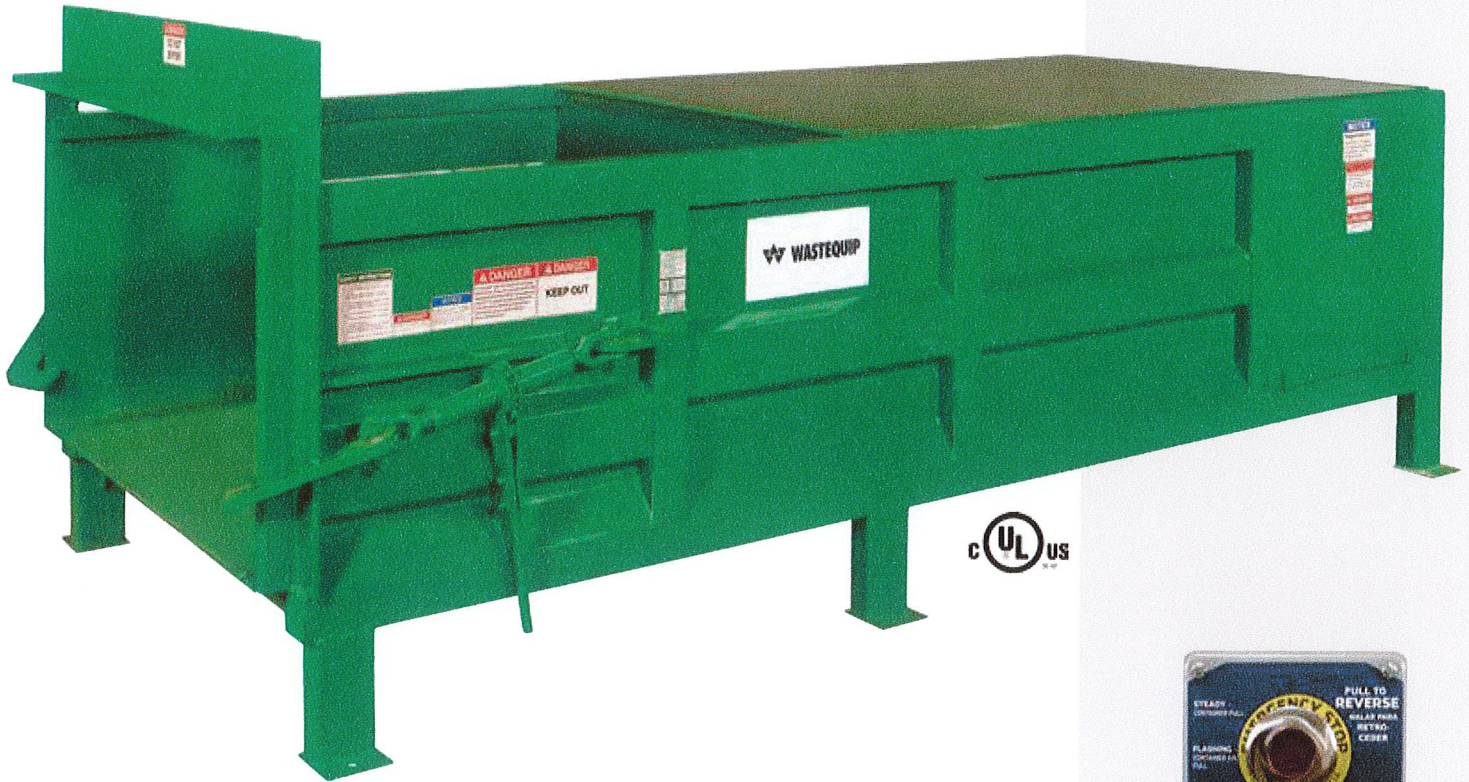

Guardian™ Control System

- New user-friendly controls
- Automatic Maintenance Tracking
- Superior 24-volt control
- NEMA 4 rated enclosure
- Remote power unit with weather protection cover

Heavy-Duty Ratchet Binders

- 1" thick hooks
- Greasable fittings

Performance

- 14" ram penetration minimizes spring-back of material
- Heavy-duty 8" x 8" x 1" breaker bar

Large-Access Openings for Maintenance and Service

- Removable rear panel
- Removable side panels



Easy-to-use 24-volt Guardian Control System (optional remote pendant shown)

** Use of an oil heater or extreme cold weather hydraulic oil is recommended in extreme cold conditions.*

STATIONARY COMPACTORS

445HD & 445XHD

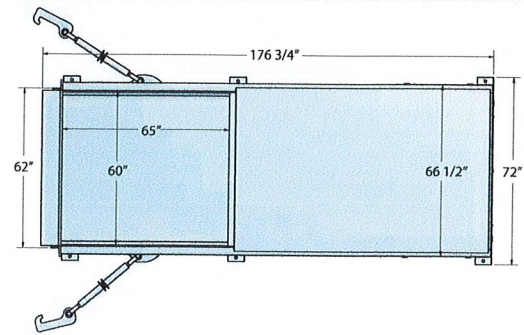
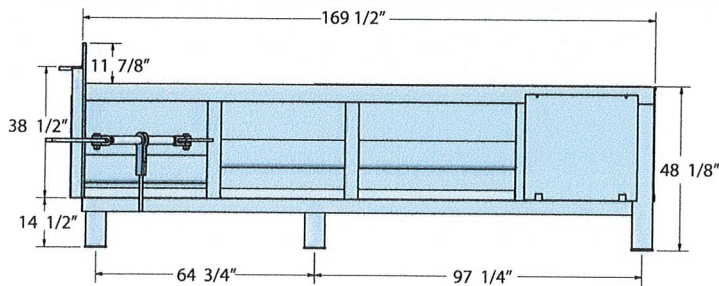

Standard Features

- 1/2" thick ram floor
- 57-second cycle time
- Controls in panel face
- Automatic Maintenance Tracking
- Full container light
- Low temperature oil
- Multi-cycle timer
- Operational and service manual
- NEMA 4 control panel protects against windblown dust, splashing water, and hose-directed water
- Primed and painted in multiple colors
- Remote power unit with weather cover

Options

- Advance warning light
- Color-coded pressure gauge
- Guide rails with/without stops
- Oil heater
- Photo electric eye
- Odor control system
- Cart dumper
- Biodegradable oil

Warranty

- 3-1-1 warranty (3-year structural, 1-year parts, 1-year labor)



Replacement parts available online at www.gotoparts.com.

Specifications

		445HD	445XHD*
Charge Box	Wastequip rating	4.00 cu. yds.	
	Wastec rating	2.59 cu. yds.	
	Clear top opening	65" Length x 60" Width	64" Length x 60" Width
	Compactor weight with power unit	6,700 lbs.	6,900 lbs.
Ram	Ram height	30.50"	
	Ram penetration	14.00"	
	Face plate	1/2" steel with 3/4" stiffener plates	
	Base plate	3/8" steel with 10 gauge formed stiffeners	
	Top plate	1/4" steel with 10 gauge formed stiffeners	
	Side plates	1/4" formed plate	
Compactor Head	Floor	1/2" steel with 10 gauge channels at 12" spacing	
	Sides	1/4" steel formed vertical stiffeners and formed horizontal stiffeners	1/4" steel formed vertical stiffeners and formed horizontal stiffeners; side stiffeners, gussets in discharge area
	Breaker bar	8" x 8", 1" angled steel	1" thick breaker bar plate
	Top deck	12 gauge steel (standard)	
Electrical	Electric motor, fan cooled	15 hp	
	Voltage	208/230/460, 3 phase 60 Hz	
	Power box	UL rated, TEFC housing	
	Automated cycle operation	Push-button start extends, retracts & stops automatically	
Hydraulic Performance	Pump	16.4 gpm	
	Pump type	Fixed gear	
	Hydraulic oil tank	25-gallon reservoir	
	Cylinder bore/rod/stroke	6.25" bore, 4.75" rod, 80" stroke	
	Normal ram face pressure	52,100 lbs.	64,400 lbs.
	Max. ram face pressure	56,500 lbs.	70,500 lbs.
	Normal ram psi	28.47 psi	35.19 psi
	Maximum ram psi	31.80 psi	38.52 psi
	Cubic yards per hour	164	
	Power unit location	Remote	
Cycle time	57 seconds		

* Specifications are the same as the 445HD, except where indicated.

Standard Color Choices

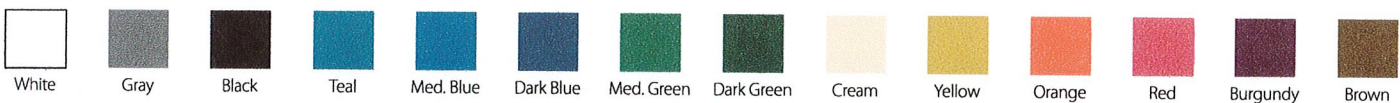

Colors shown are as accurate as printing allows. The actual color is subject to variation from the printed color sample. Color choices vary by plant location. Please contact your local sales representative for available colors. Custom colors are available upon request and are subject to an additional charge.



Tel: 877.468.9278 | sales@wastequip.com | www.wastequip.com

Wastequip is the leading North American manufacturer of waste and recycling equipment for collecting, processing, and transporting recyclables and solid or liquid waste. © Wastequip. All rights reserved. Specifications subject to improvement without notice. Equipment displayed should be operated by properly trained personnel. Operators should become familiar with OSHA, ANSI, and any other applicable standards or laws for using this equipment. Improper use, misuse, or lack of maintenance could cause injury to people and/or property. Photos used in the literature are illustrative only. We assume no liability or responsibility for proper training/operation of equipment not manufactured by Wastequip. We reserve the right to make changes at any time without notice. Information contained within this literature is intended to be the most accurate available at time of printing.



Electric Wiring Chart

Required Electrical Power Information

A separate branch circuit with a main disconnect device supplied by the owner is required to supply power to compactor and baler power units. The installation of the main disconnect must be performed by a qualified electrician in compliance with all local and National Electrical Code regulations. ANSI standards require that the main "disconnect shall be located within sight of, and no more than 50 feet away from the main control panel." The actual voltage must be within +/-5% of the nameplate rating on the motor when the unit is operating at the system relief pressure. The following table lists minimum and recommended fuse and wire sizes for the various motors used on compaction and baling equipment manufactured by Wastequip, LLC.

Motor Horsepower Rating Phase	Line Supply Voltage	Full Load Amps ¹	Locked Rotor Amps ²	Maximum Dual Element Time Delay Fuse ³	Minimum Disconnect Rating ⁴	Minimum Wire Size THHN CU 90°C / 194°F ⁵			Recommended Wire Size THHN CU / 194°F * Denotes same as minimum		
						100'	200'	300'	100'	200'	300'
2HP 1 Phase	115/60Hz	24.0	144.0	45.0	60.0	8	6	4	*	*	*
	208/60Hz	13.2	80.0	25.0	30.0	12	10	8	10	8	6
	230/60Hz	12.0	72.0	25.0	30.0	12	10	8	10	8	6
3HP 1 Phase	115/60Hz	34.0	204.0	60.0	60.0	6	4	3	*	*	*
	208/60Hz	18.7	113.0	35.0	60.0	10	8	6	*	*	*
	230/60Hz	17.0	102.0	30.0	30.0	12	10	8	10	8	6
5HP/1 Phase	230/60Hz	28.0	168.0	50.0	60.0	8	6	4	*	*	*
10HP/1 Phase	230/60Hz	50.0	300.0	90.0	100.0	4	3	2	*	*	*
3HP 3 Phase	208/60Hz	10.6	71.0	20.0	30.0	14	12	10	12	10	8
	230/60Hz	9.6	64.0	20.0	30.0	14	12	10	12	10	8
	460/60Hz	4.8	32.0	10.0	30.0	14	12	10	*	*	*
	575/60Hz	3.9	25.6	10.0	30.0	14	12	10	*	*	*
5HP 3 Phase	208/60Hz	16.7	102.0	30.0	30.0	12	10	8	10	8	6
	230/60Hz	15.2	92.0	30.0	30.0	12	10	8	10	8	6
	460/60Hz	7.6	46.0	15.0	30.0	14	12	10	*	*	*
	575/60Hz	6.1	36.8	15.0	30.0	14	12	10	*	*	*
10HP 3 Phase	208/60Hz	30.8	179.0	60.0	60.0	6	4	3	*	*	*
	230/60Hz	28.0	162.0	50.0	60.0	8	6	4	*	*	*
	460/60Hz	14.0	81.0	25.0	30.0	12	10	8	10	8	6
	575/60Hz	11.0	64.8	20.0	30.0	14	12	10	12	10	8
15HP 3 Phase	208/60Hz	46.2	257.0	90.0	100.0	4	3	2	*	*	*
	230/60Hz	42.0	232.0	80.0	100.0	4	3	2	*	*	*
	460/60Hz	21.0	116.0	40.0	60.0	10	8	6	8	6	4
	575/60Hz	17.0	93.0	30.0	30.0	12	10	8	10	8	6
20HP 3 Phase	208/60Hz	59.4	321.0	110.0	200.0	3	2	1	*	*	*
	230/60Hz	54.0	290.0	100.0	100.0	3	2	1	*	*	*
	460/60Hz	27.0	145.0	50.0	60.0	8	6	4	*	*	*
	575/60Hz	22.0	116.0	40.0	60.0	10	8	6	8	6	4
30HP 3 Phase	230/60Hz	80.0	435.0	150.0	200.0	1/0	2/0	3/0	*	*	*
	460/60Hz	40.0	218.0	70.0	100.0	6	4	3	*	*	*
	575/60Hz	32.0	174.0	60.0	60.0	6	4	3	*	*	*
50HP 3 Phase	230/60Hz	130.0	725.0	250.0	400.0	4/0	250	300	*	*	*
	460/60Hz	65.0	363.0	125.0	200.0	2	1	1/0	*	*	*
	575/60Hz	52.0	290.0	100.0	100.0	3	2	1	*	*	*

1. Values for single phase motors obtained from Table 430.248 of 2014 NEC. Values for three phase motors obtained from Table 430.250 of 2014 NEC.

2. Values for single phase motors obtained from Table 430.251(A) of 2014 NEC. Values for three phase motors obtained from Table 430.251(B) of 2014 NEC.

3. Maximum fuse values are based on full load X 175% (300% for class CC) as determined from Table 430.52 of 2014 NEC. The fuse and wire sizes must always meet or exceed any federal, state, or local electrical codes or ordinances.

4. Minimum disconnect rating is the greater of the full load current X 115% as determined from Article 430.110 of 2014 NEC and the maximum overcurrent protection. It is the owner's/installer's responsibility to verify disconnect used is rated for correct horsepower motor at the supply voltage used.

5. Wire size based on motor full load current X 125% and ampacity of 90 degrees THHN copper wire found in Table 310.15(B)(16) of NEC 2014. When minimum wire size is rated below the maximum fuse size, the next wire size up will be used. Wire must not introduce more than 5% voltage drop. Check federal, state, or local electrical codes or ordinances.



Electric Wiring Chart

Required Electrical Power Information

A separate branch circuit with a main disconnect device supplied by the owner is required to supply power to compactor and baler power units. The installation of the main disconnect must be performed by a qualified electrician in compliance with all local and National Electrical Code regulations. ANSI standards require that the main "disconnect shall be located within sight of, and no more than 50 feet away from the main control panel." The actual voltage must be within +/-5% of the nameplate rating on the motor when the unit is operating at the system relief pressure. The following table lists minimum and recommended fuse and wire sizes for the various motors used on compaction and baling equipment manufactured by Wastequip, LLC.

Motor Horsepower Rating Phase	Line Supply Voltage	Full Load Amps ¹	Locked Rotor Amps ²	Maximum Dual Element Time Delay Fuse ³	Minimum Disconnect Rating ⁴	Minimum Wire Size THHN CU 90°C / 194°F ⁵			Recommended Wire Size THHN CU / 194°F * Denotes same as minimum		
						100'	200'	300'	100'	200'	300'
2HP 1 Phase	115/60Hz	24.0	144.0	45.0	60.0	8	6	4	*	*	*
	208/60Hz	13.2	80.0	25.0	30.0	12	10	8	10	8	6
	230/60Hz	12.0	72.0	25.0	30.0	12	10	8	10	8	6
3HP 1 Phase	115/60Hz	34.0	204.0	60.0	60.0	6	4	3	*	*	*
	208/60Hz	18.7	113.0	35.0	60.0	10	8	6	*	*	*
	230/60Hz	17.0	102.0	30.0	30.0	12	10	8	10	8	6
5HP/1 Phase	230/60Hz	28.0	168.0	50.0	60.0	8	6	4	*	*	*
10HP/1 Phase	230/60Hz	50.0	300.0	90.0	100.0	4	3	2	*	*	*
3HP 3 Phase	208/60Hz	10.6	71.0	20.0	30.0	14	12	10	12	10	8
	230/60Hz	9.6	64.0	20.0	30.0	14	12	10	12	10	8
	460/60Hz	4.8	32.0	10.0	30.0	14	12	10	*	*	*
	575/60Hz	3.9	25.6	10.0	30.0	14	12	10	*	*	*
5HP 3 Phase	208/60Hz	16.7	102.0	30.0	30.0	12	10	8	10	8	6
	230/60Hz	15.2	92.0	30.0	30.0	12	10	8	10	8	6
	460/60Hz	7.6	46.0	15.0	30.0	14	12	10	*	*	*
	575/60Hz	6.1	36.8	15.0	30.0	14	12	10	*	*	*
10HP 3 Phase	208/60Hz	30.8	179.0	60.0	60.0	6	4	3	*	*	*
	230/60Hz	28.0	162.0	50.0	60.0	8	6	4	*	*	*
	460/60Hz	14.0	81.0	25.0	30.0	12	10	8	10	8	6
	575/60Hz	11.0	64.8	20.0	30.0	14	12	10	12	10	8
15HP 3 Phase	208/60Hz	46.2	257.0	90.0	100.0	4	3	2	*	*	*
	230/60Hz	42.0	232.0	80.0	100.0	4	3	2	*	*	*
	460/60Hz	21.0	116.0	40.0	60.0	10	8	6	8	6	4
	575/60Hz	17.0	93.0	30.0	30.0	12	10	8	10	8	6
20HP 3 Phase	208/60Hz	59.4	321.0	110.0	200.0	3	2	1	*	*	*
	230/60Hz	54.0	290.0	100.0	100.0	3	2	1	*	*	*
	460/60Hz	27.0	145.0	50.0	60.0	8	6	4	*	*	*
	575/60Hz	22.0	116.0	40.0	60.0	10	8	6	8	6	4
30HP 3 Phase	230/60Hz	80.0	435.0	150.0	200.0	1/0	2/0	3/0	*	*	*
	460/60Hz	40.0	218.0	70.0	100.0	6	4	3	*	*	*
	575/60Hz	32.0	174.0	60.0	60.0	6	4	3	*	*	*
50HP 3 Phase	230/60Hz	130.0	725.0	250.0	400.0	4/0	250	300	*	*	*
	460/60Hz	65.0	363.0	125.0	200.0	2	1	1/0	*	*	*
	575/60Hz	52.0	290.0	100.0	100.0	3	2	1	*	*	*

1. Values for single phase motors obtained from Table 430.248 of 2014 NEC. Values for three phase motors obtained from Table 430.250 of 2014 NEC.

2. Values for single phase motors obtained from Table 430.251(A) of 2014 NEC. Values for three phase motors obtained from Table 430.251(B) of 2014 NEC.

3. Maximum fuse values are based on full load X 175% (300% for class CC) as determined from Table 430.52 of 2014 NEC. The fuse and wire sizes must always meet or exceed any federal, state, or local electrical codes or ordinances.

4. Minimum disconnect rating is the greater of the full load current X 115% as determined from Article 430.110 of 2014 NEC and the maximum overcurrent protection. It is the owner's/installer's responsibility to verify disconnect used is rated for correct horsepower motor at the supply voltage used.

5. Wire size based on motor full load current X 125% and ampacity of 90 degrees THHN copper wire found in Table 310.15(B)(16) of NEC 2014. When minimum wire size is rated below the maximum fuse size, the next wire size up will be used. Wire must not introduce more than 5% voltage drop. Check federal, state, or local electrical codes or ordinances.

OCTAGON PACKER RECEIVER

Octagon Receivers are engineered to withstand the repeated pressures and abuse of compactors. Designed to provide **LONG-LASTING, DEPENDABLE** performance for high-volume refuse accounts.

Compatible with most major brand roll-off systems.

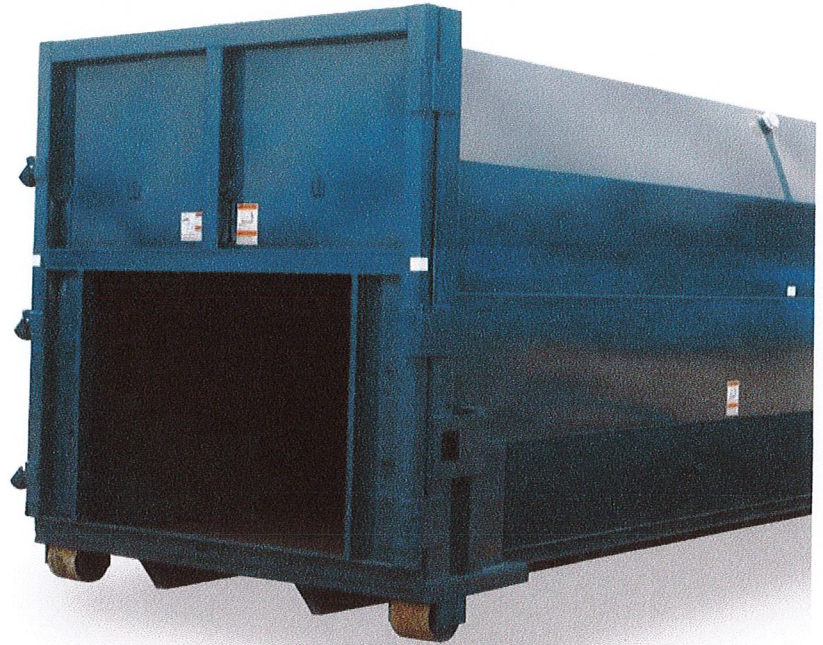

FEATURES & BENEFITS

- 7 gauge floor with 3" structural channels on 18" centers
- 7 gauge lower front and sides
- 10 gauge upper front and sides
- ANSI-compatible opening
- Painted any standard color
- Several sizes and hookup options available

877.468.9278
sales@wastequip.com
www.wastequip.com



OCTAGON PACKER RECEIVER

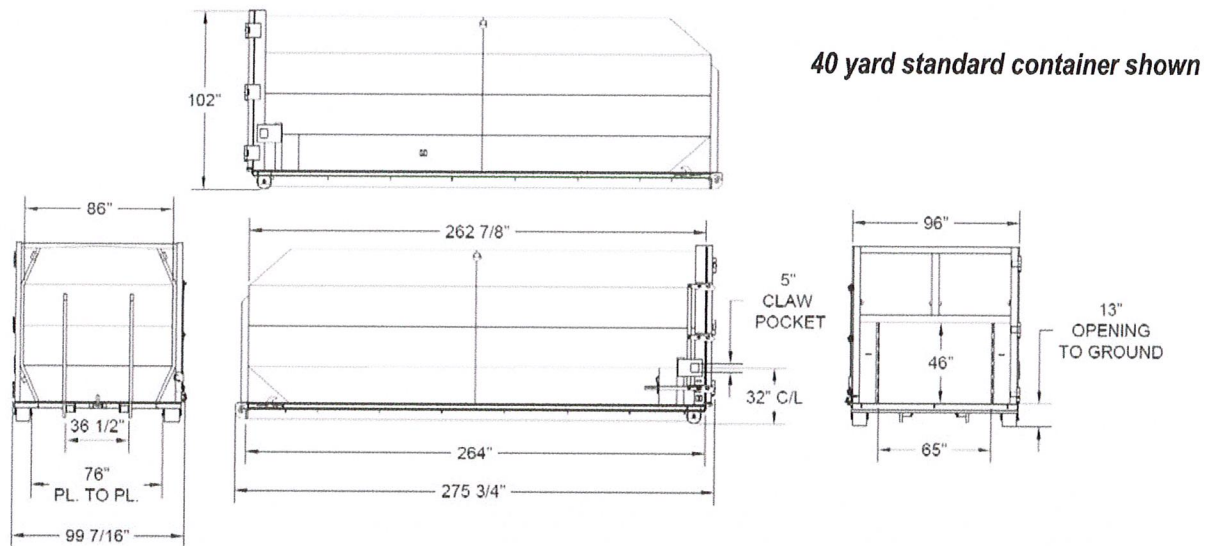

40 yard standard container shown

Outside Dimensions				Rated Capacity Cubic Yards	Approximate Shipping Weight
Description	Length	Width	Height		
20-Yard OCT	15'	100"	86"	20	4,600 lbs.
30-Yard OCT	17' 7"	100"	102"	30	5,500 lbs.
40-Yard OCT	23'	100"	102"	40	7,024 lbs.

Options
Front wheels
Belly bands
Crash Plate
Ratchet binder in place of standard latch
HD or XHD specs. available for larger compactors
Painted any standard color- special colors available upon request

Standard Specifications
Floor: 7 gauge with 3" structural channels on 18" centers and 6" x 2" x 3/16" structural tubing main rails
Front and Sides: 7 gauge lower front and sides and 10 gauge upper front and sides
Standard: 40 yard has maximum payload of 60,000 lbs. and a maximum force rate of 70,000 lbs. ANSI-compatible opening 13" to ground. 46" tall X 65" wide opening. Other sizes available.

Standard Color Choices*

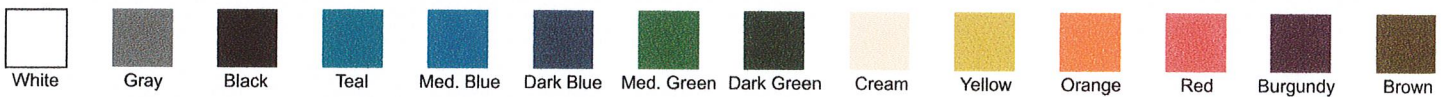

Colors shown are as accurate as printing allows. The actual color is subject to variation from the printed color sample. Color choices vary by plant location. Please contact your local sales representative for available colors. Custom colors are available upon request and are subject to an additional charge.



Tel: 877.468.9278 | sales@wastequip.com | www.wastequip.com

Wastequip is the leading North American manufacturer of waste and recycling equipment for collecting, processing and transporting recyclables and solid or liquid waste. © July 2015 Wastequip, all rights reserved. Specifications subject to improvement without notice. Equipment displayed should be operated by properly trained personnel. Operators should become familiar with OSHA, ANSI and any other applicable standards or laws for using this equipment. Improper use, misuse, or lack of maintenance could cause injury to people and/or property. Photos used in the literature are illustrative only. We assume no liability or responsibility for proper training/operation of equipment not manufactured by Wastequip. We reserve the right to make changes at any time without notice. Information contained within this literature is intended to be the most accurate available at time of printing.

WQP068-072015

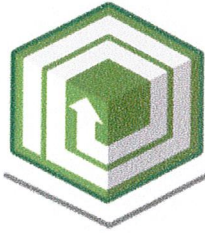

ATLANTIC RECYCLING EQUIPMENT

WE **A.R.E.** YOUR EQUIPMENT SPECIALISTS

Installation References.

1. **Town of Gilmanton, NH** – Transfer Station – New 445HD Compactor and hopper system. – Contact: Heidi Duval – Town Administrator 603-267-6700
2. **Town of Cape Elizabeth, ME** – Five (5) New 445XHD Compactors w/ Dog Houses. Contact: Robert Malley – 207-799-4151
3. **Town of Rockingham, VT** – One (1) New 445XHD Compactor & Dog House. Contact: Shane O’Keefe – 802-463-3964 ext 1104
4. **Town of Epping, NH** – Three (3) – 445HD Compactors with hoppers & Dog Houses. Contact: David Rienhold – Mobile: 603-608-9488
5. **Town of Deerfield, NH** – Four (4) – 445HD Compactors with rear feed chute systems. Contact: Rick Pelletier – Mobile: 603-566-8985
6. **Town of Norwich, VT** – Two (2) – 445HD Compactors with Dog Houses. Contact: Andy Hodgkins – 802-649-2209
7. **Town of Freeport, ME** – One (1) – 445HD Compactor with Dog House. Contact: Sandy Duplissis – 207-865-3740

TOWN OF WEATHERSFIELD
REQUEST FOR BIDS FOR
TRASH COMPACTOR, INSTALLATION, AND CONCRETE PAD

Bidders name, address, email address, and phone number:

ATLANTIC Recycling EQUIPMENT, LLC
13 Jessie Doe Road
Rollinsford, NH 03869-0609
Todd Hagen, Owner

List similar work bidder has successfully completed:

Please See Attached Reference Sheet

Cost of Compactor \$ 29,010.⁰⁰
Installation \$ 3,500⁰⁰
Cost of Concrete Pad Replacement \$ NO BID
Total Cost of Project \$ 32,510⁰⁰ w/o Container
Certified date for completion of the delivery and installation: First week of October, 2022, no later than wk of 10/3/2022

Technical specifications for proposed units is required.

Please See ATTACHED Spec sheets

The undersigned, having familiarized themselves with the conditions of project as set forth in the Request for Bids, hereby proposes to furnish all supervision, technical personnel, labor, materials, tools, appurtenances, equipment, and services required to perform the required project, all for the TOTAL COST of this bid.

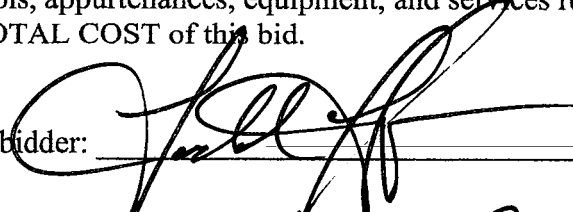
Signature of bidder: 

Date: 6/30/2022

Name of bidder: Todd Hagen, Owner

Insurance Certificates & W-9 will be provided if we are awarded
The Bid.

TOWN OF WEATHERSFIELD
APPLICATION FOR ENTERTAINMENT PERMIT
PERMITS EXPIRE ON APRIL 30TH ANNUALLY

Name: _____

Lynn Esty
2520 VT RT 106

Business Mailing Address: _____

Perkinsville, VT 05151-9333

Telephone Number: _____

802-738-7413

Business Name: _____

N/A

Event Location: _____

Salmond Covered Bridge, Henry Gould Rd

Telephone Number: _____

802-738-7413

Application is for [check one]



Permanent Use



Occasional Use



One Time Use

Describe the area where entertainment will be conducted, and type of entertainment:

we wish to hold a wedding inside the bridge

Times and Days entertainment will be provided:

Saturday, October 8, 2022 12 noon to 2pm

Application No. _____

Date Submitted: _____

Fee Paid: _____

Action by Board of Selectmen: _____



Approved



Denied

Date of Action: _____

Conditions [If applicable] _____

Selectboard Chairperson: _____

Lynn Esty
2520 VT Rt 106
Perkinsville, VT 05151-9333
802-738-7413

Town of Weathersfield
PO Box 519
Ascutney, VT 05030-0519

Application for Entertainment Permit

I wish for permission to occupy the Salmond Covered Bridge on Henry Gould Road for a wedding on Saturday, October 8, 2022 from 12 noon to 2 pm. There will be approximately 50 people in attendance.

The Salmond Covered Bridge park will also be utilized for seating and pictures.

As a result of occupying the Salmond Covered Bridge, Henry Gould Road would be closed between 230 Henry Gould Road and 64 Henry Gould Road. Both 230 and 64 Henry Gould Road will remain accessible to VT Route 131. There are no other driveways and/or residences between the closure points. (Please see enclosed closure point map.)

Closure will be made in the form of traffic cones and/or highway closure signs; or any other form as dictated by the Town of Weathersfield Highway Department.

Parking will be along the closed portion of Henry Gould Road and the parking area on VT Route 131. No driveways will be blocked and/or impeded.

There will not be any combustible heat sources within the confines of the bridge. Proposed lighting inside the bridge will be strings of battery-operated miniature colored lights, as well as small battery-operated votive candles in baskets of live flowers.

Proposed music will be played via Blue Tooth Speaker and/or cell phone.

'Confetti' will consist of biodegradable leaves and flower petals.

In the event of an emergency, the entire neighborhood is accessible to emergency vehicles. The Fire Department and Ambulance would not cross the bridge, accessing all residents either by Henry Gould Road to the south or Ascutney Notch Road to the north of the Salmond Covered Bridge, both off VT Route 131.

Thank you for your consideration in this matter.

If you have any further questions, please do not hesitate to contact me.

Lynn Esty

ENTERTAINMENT PERMIT

In reference to the application for entertainment permit for the Saturday, October 8, 2022, event from 12pm-2pm, please sign below if you have reviewed and approve of the application.

Police Chief

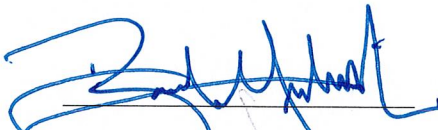

AVFA Fire Chief

WWVFD Fire Chief

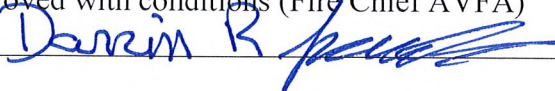

Town Manager

Approved with conditions (Police Chief)

Approved with conditions (Fire Chief AVFA)

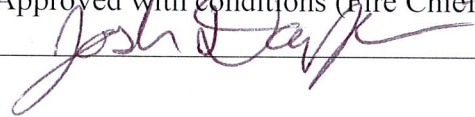

Approved with conditions (Fire Chief WWVFD)



Approved with conditions (Town Manager)

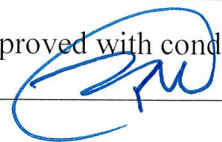



TOWN OF WEATHERSFIELD

5259 US ROUTE 5

ASCUTNEY, VERMONT 05030

Selectboard

Michael Todd
David Fuller
Kelly O'Brien
Paul Tillman
Wendy Smith

Brandon Gulnick
Town Manager
TEL. (802) 674-2626
Weathersfieldvt.org

May 26, 2022

Board members,

During the May 16th Selectboard meeting the board requested that we organize high priority building improvements identified in the Town-Wide Building Assessment presentation and develop a summary report. The purpose of this report is to identify these high priority areas and request action from the board to obtain estimates on the priorities the board deems appropriate.

1. 1879 School House

The 1879 Schoolhouse is 143 years old. The building is 2030 SQFT and has 2 floors. The replacement value of the building is \$687,475. The purpose of the building has not been defined, however, some of the space has been designated as a Food Shelf. The structural system of the building includes flagstone, a stone foundation, brick, and wood walls. The building is in good condition.

High Priorities

- Roof replacement - likely installed in 1900, the roof is nearly 120 years old.
- Fire Alarm System - no existing fire alarm system
- Removal of flammable wall surface in food shelf. Old beaverboard needs to be removed and plaster repaired.
- Pave the walk from the parking lot to the building to improve accessibility for Americans with Disabilities.
- Install motion detector lights.
- Install storm windows to improve energy efficiency.
- Replace wood doors.
- Install heat/cooling pumps.
- Convert interior lighting to LED - improves energy efficiency and visibility.

2. Ascutney Fire Station

The Ascutney Fire Station is 20 years old. The building is 4,550 SQFT and has 2 floors. The replacement value of the building is \$586,790. The purpose of the building is Emergency Services. The owner of the building is the Ascutney Volunteer Fire Association, and the owner of the land is the State of Vermont. The building is in good condition.

2. Ascutney Fire Station Continued...

High Priorities

- Install floor drain with an oil separator. Water leaks in through garage door.
- Water contains high salt & iron. Replace well or extend Water District main line.
- Install heating system, infrared tube heaters - works from propane, run length of bays
- Install a Fume-A-Vent system
- Install heating & cooling pumps

3. Martin Memorial Hall

Martin Memorial Hall is 60 years old. The building is 4,800 SQFT and has 2 floors. The replacement value of the building is \$1,110,358. The purpose of the building is Town Offices/ Community use. The owner of the building is the Town of Weathersfield. The building envelope consists of wood/vinyl/brick and the structural system is wood/brick. The building is in good condition.

High Priorities

- Roof Replacement - existing roof is in poor condition.
- Replace 13 single pane windows.
- Install heat & cooling pumps - eliminates window air conditioner units & increases energy efficiency.
- Install LED lighting
- Install Key Fob Lock system on doors and cash register
- Install a generator
- Pave driveway and parking lot (Wragg Brothers willing to partner with the Town)

4. West Weathersfield Fire Station

The West Weathersfield Fire Station is 54 years old. The building is 2,680 SQFT and has 1 floor. The replacement value of the building is \$426,893. The purpose of the building is Emergency Services. The owner of the building is the West Weathersfield Volunteer Fire Department; however, the department is willing to sign it over to the Town of Weathersfield. The building envelope is metal, and the structural system is steel. The building is in fair condition.

High Priorities

- Replace Roof, flashing, and sealants.
- Replace 4 windows.
- Replace exterior doors.
- Remove ceiling, reinsulate, and use sheetrock (after roof replacement)
- Install Fume-A-Vent System
- Wire the garage doors to work with the generator when power is out.

5. **Proctor Library**

The Weathersfield Proctor Library is 120 years old. The building is 1,497 SQFT and has 2 floors including the basement office level. The replacement value of the building is \$250,829. The purpose of the building is library - public use. The building is in good condition.

High Priorities

- Install hard pack, install drain, and rise up parking lot.
- Install motion lighting on the exterior.
- Replace 8 windows.
- Install foyer on outside of building. Significant energy loss when front door opens.
- Inspect roof to determine whether it requires replacement.
- Install drainage system or seal basement. Water leaking in through brick.
- Install fire alarms.
- Install LED lights. Existing lighting is poor.

6. **Town Garage**

The Town Garage is 49 years old. The building is 7,440 SQFT and has 1 floor. The replacement value of the building is \$1,063,271. The purpose of the building is storage & repairs. The building envelope & structural system is wood & metal. The building is in fair/poor condition.

High Priorities

- Replace roof, flashing, downspouts, and sealants.
- Replace SE wall.
- Replace garage doors.
- Replace water supply artesian well, and water heater.
- Insulate ceilings, seal areas around garage doors.
- Install 3 floor drains with couplings to run drains from roof with oil separator.
- Install salt shed.
- Replace all lighting with LED.
- Replace all entrance doors.
- Install cement knee, wall length of breakroom, 2 ft high/30ft long to prevent salt and water from seeping into breakroom, which will lead to rot.
- Install Fire Alarm system.

7. **Transfer Station**

The Transfer Station is 32 years old. The buildings are 2,264 SQFT and have 1 floor. The replacement value of the buildings is \$74,328. The purpose of the facility is public recycling & waste disposal. Building envelop & structural system is wood.

Continued on next page

7. Transfer Station Continued...

High Priorities

- Move entry gate 20 ft and install new fence and gate.
- Replace cement pad lower than ground level.
- Replace trash compactor.
- Install guard rail to surround compactor.
- Replace 500-gallon oil tank.
- Install cameras on inside and outside of buildings with alarm.
- Install fire alarms.

SUMMARY

Overall, 4/7 buildings currently require a roof replacement and 1 should be inspected to determine whether the roof needs to be replaced. Replacing these roofs will improve the longevity of the buildings. Another reoccurring issue is lighting. Replacing the existing lighting with LED will improve energy efficiency and visibility. Overall, 25 windows need to be replaced within 3 of our buildings. This will improve energy efficiency and longevity. The Town Garage is in the poorest condition in relation to the other 6 buildings assessed, and the West Weathersfield Fire Station follows closely behind it. The other 5 buildings are in relatively good shape, however, the high priority items identified will improve their longevity.



Town of Weathersfield

5259 US ROUTE 5 | P.O. BOX 550 | WEATHERSFIELD, VT 05030 | PHONE (802) 674-2626 | FAX (802) 674-2117

Brandon Gulnick
Town Manager

June 2, 2022

RE: Business Personal Property Tax

The Town of Weathersfield taxes for Business Personal Property per 32 V.S.A. § 3618.

- A. If a Town does not vote to exempt business personal property under 3849 of this title, such property shall be appraised at fair market value; or, subject to a majority vote of those present and voting at an annual or special meeting warned for the purpose, a Town may provide that business personal property shall be appraised for any taxable year according to either of the following methods, which may be elected at the option of the taxpayer:
- (1) At 50 percent of its cost during the time that it has not been fully depreciated for federal income tax purposes under the laws of the United States. After the property has been thus depreciated, exclusive of salvage value, for federal income tax purposes, it shall be appraised at 10 percent of its cost;
 - (2) At its net book value during the time that it has not been depreciated to 10 percent of its cost or less for federal income tax purposes under the laws of the United States. After the property has been depreciated to 10 percent of its cost or less, exclusive of salvage value, for federal income tax purposes, it shall be appraised at 10 percent of its cost. Business personal property manufactured by the taxpayer for his or her own use, shall be valued at the net book value for federal income tax purposes under the laws of the United States. After the property has been depreciated to 10 percent of its cost or less, exclusive of salvage value, for federal income tax purposes, it shall be appraised at 10 percent of its cost.
- B. The taxpayer may elect either of the methods set forth in subsection (a) of this section in the first year for which this election is effective. In any subsequent year the taxpayer may not change the method elected in the previous year except with the prior permission of the board of listers. All of the taxpayer's business personal property shall be valued for any year according to only one of the two methods. Adjustments by the taxpayer or the federal authorities of the depreciation allowed or allowable on the property, for federal income tax purposes, shall not affect or change the appraisal of the property under this section for any year as to which, at the time of the adjustment in depreciation, the grand list has been lodged as required by section 4151 of this title.

Continued on next page...

C. As used in this section:

- (1) "Business personal property" means tangible personal property of a depreciable nature used or held for use in any trade, business, professional practice, transaction, activity, or occupation conducted for profit, including all furniture and fixtures, apparatus, tools, implements, books, machines, boats, construction devices, and all personal property used or intended to be used for the production, processing, fabrication, assembling, handling, or transportation of anything of value, or for the production, transmission, control, or disposition of power, energy, heat, light, water, or waste. "Business personal property" does not include inventory, or goods and chattels so affixed to real property as to have become part thereof, and that are therefore not severable or removable without material injury to the real property, nor does it include poles, lines, and fixtures that are taxable under sections 3620 and 3659 of this title.

- (2) "Net book value" of property means the cost less depreciation of the property as shown on the federal income tax return required to be filed with the federal authorities on or nearest in advance of April 1 in any year. (Added 1975, No. 101, § 2, eff. April 30, 1975; amended 1985, No. 169 (Adj. Sess.), § 3, eff. May 5, 1986; 1991, No. 203 (Adj. Sess.), § 4, eff. May 27, 1992.)

See Attachment A – Vermont Personal Property Form

Brandon Gulnick
Town Manager

ATTACHMENT A
[VERMONT PERSONAL PROPERTY FORM]

VERMONT PERSONAL PROPERTY
To be filed with the Weathersfield Listers on or before April 20
TOWN OF WEATHERSFIELD, VERMONT
Including Perkinsville and Ascutney
PO BOX 550
ASCUTNEY VT 05030
(802) 674-2626

NAME (please print) _____
Address to which tax notice should be sent: _____

Location(s) of Personal Property _____

STATUTORY PROVISIONS

Title 32, Section 4006 - A taxpayer required by law to make and return an inventory who refuses to sign, swear to or affirm such inventory shall be fined.

Title 32, Section 4084 - When taxable property of such person is not ascertainable by the listers, they shall appraise the property of such person at a sum which, in their judgement, is the fair market value of all the taxable property owned by him.

It is the duty of the taxpayer to obtain this blank form from the Town Clerk or Listers, fill out the same and return it to the Listers by April 20th. If he or she aids you, he or she does it as a service, and not because it is his or her legal duty. The taxpayer's cooperation is solicited.

DIRECTIONS

1. Fill out the above block, making sure the name and mailing address are correct for billing purposes.
2. Fill out the reverse side of this form, after choosing Method #1 or #2 listed below.
3. The form must be signed by the responsible individual or officer and dated.

BUSINESS PERSONAL PROPERTY

When the Inventory Tax was eliminated, state law required that Business Personal Property, which includes among other items, machinery, equipment, furniture and fixtures, apparatus, tools, implements, books, machines, boats, construction devices, and all personal property used or intended to be used for the production, processing, fabrication, assembling, handling or transportation of anything of value, or for the production, transmission, control or disposition of power, energy, heat, light, water or waste (reference, Title 32 VSA section 3618), be assessed by a cost less depreciation method rather than Fair Market Value. The taxpayer is requested to elect one of the following methods:

Method #1 - At fifty percent of its cost during the time that it has not been fully depreciated for federal income tax purposes under the laws of the United States. After the property has been thus depreciated, exclusive of salvage value, for federal income tax purposes, it shall be appraised at ten percent of its cost; or

Method #2 - At its net book value during the time that it has not been depreciated to ten percent of its cost or less for federal income tax purposes under the laws of the United States. After the property has been depreciated to ten percent of its cost or less, exclusive of salvage value, for federal income tax purposes, it shall be appraised at ten percent of its cost.

IMPORTANT - PLEASE INDICATE YOUR SELECTION BY CIRCLING #1 OR #2. If you have any questions, please feel free to call the Listers Office at 674-2626.

SIGNATURE REQUIRED

I do solemnly swear (or affirm), under the pains and penalties of perjury, that to my knowledge and belief, the inventory herein by me subscribed is a full, true and correct list and description of all personal property which should be set in the list to me. (32VSA Section 4002 and 4006)

Signature _____
Date _____

FOR LISTERS USE ONLY

ASSESSED VALUE:

Equipment: _____

Date form was returned _____

Signature of person who received the form _____

YEAR _____

TAXABLE PERSONAL PROPERTY

Similar items may be grouped by year of purchase. A separate line should be used for items fully depreciated for IRS purposes. Cost includes all costs accrued to all taxable items. When purchased Aused@, indicate by Au@ after cost. If owner=s value differs substantially from depreciated cost please explain. List all taxable personal property located in our town on April 1, which was owned by you or in your charge, if you are responsible for property taxes on it.

Equipment:

- Manufacturing equipment not, by law, set as real estate
- Office, store, shop or other furniture & equipment
- Gasoline pumps w/tanks if not listed as real estate (if by terms of lease, you do not pay tax, give name & address of owner)
- Other machinery and equipment (hand tools not included)
- Household furniture and equipment used for income producing purposes (such as motel furnishings, laundromat equipment, etc.)

<u>EQUIPMENT</u>	<u>YEAR ACQUIRED</u>	<u>COST</u>	<u>ACCUM. DEPREC.</u> May not exceed 90%	<u>DEPREC. BOOK VALUE</u> A0" is not an acceptable entry

LEASES - Please list -

Leased from (name & address):	Item leased	Length of lease	Monthly payment
1. _____ _____	_____	_____	_____
2. _____ _____	_____	_____	_____

Meeting date
 AP warrant date
 Payroll warrant date 1
 Payroll warrant date 2
 Payroll warrant date 3

July 5, 2022
 07/05/22
 06/23/22
 06/30/22



TOWN OF WEATHERSFIELD, VERMONT

Warrants for Meeting of July 5, 2022

	Check Date	Payroll	Operating Expenses
General Fund			
	6/23/2022	\$8,158.10	
	6/30/2022	\$8,397.28	
AP	7/5/2022		\$42,373.47
Total		\$16,555.38	\$42,373.47
Highway Fund			
	6/23/2022	\$3,970.76	
	6/30/2022	\$3,916.44	
AP	7/5/2022		\$79,665.94
		\$7,887.20	\$79,665.94
Solid Waste Mgmt Fund			
	6/23/2022	\$940.89	
	6/30/2022	\$859.61	
AP	7/5/2022		\$219.83
Total		\$1,800.50	\$219.83
Library			
	6/23/2022	\$1,075.14	
	6/30/2022	\$995.54	
Total		\$2,070.68	\$0.00
Grants			\$13,260.32
Reserves			\$99,426.79
Grand Totals		\$28,313.76	\$234,946.35

Selector

To the Treasurer of the Town of Weathersfield, we hereby certify that there is due to the several persons whose names are listed hereon the sum against each name and that there are good and sufficient vouchers supporting the payments aggregating \$263,260.11. Let this be your order for the payments of these amounts.

Vendor	Invoice Date	Invoice Description Invoice Number	Account	Amount Paid	Check Number	Check Date
BUSINESSC	06/21/22	COMMERCIAL CARD SERVICES 5/12-6/5/22 creditcard ADMINMAY22	11-7-101-25.15 Software	120.00	225291	06/30/22
BUSINESSC	06/21/22	COMMERCIAL CARD SERVICES 5/12-6/5/22 creditcard ADMINMAY22	11-7-101-25.15 Software	14.99	225291	06/30/22
BUSINESSC	06/21/22	COMMERCIAL CARD SERVICES 5/12-6/5/22 creditcard ADMINMAY22	11-7-101-25.15 Software	15.89	225291	06/30/22
BUSINESSC	06/17/22	COMMERCIAL CARD SERVICES 5/10-5/31/22 Charge AVFDMAY22	11-7-206-31.00 Telephone & Internet	302.00	225291	06/30/22
BUSINESSC	06/17/22	COMMERCIAL CARD SERVICES 5/10-5/31/22 Charge AVFDMAY22	11-7-206-20.00 Supplies	32.14	225291	06/30/22
BUSINESSC	06/17/22	COMMERCIAL CARD SERVICES 5/13-6/5/22 Charges LIBMAY22	11-7-601-21.00 Library-Postage	15.12	225291	06/30/22
BUSINESSC	06/17/22	COMMERCIAL CARD SERVICES 5/13-6/5/22 Charges LIBMAY22	11-7-601-21.00 Library-Postage	4.23	225291	06/30/22
BUSINESSC	06/17/22	COMMERCIAL CARD SERVICES 5/13-6/5/22 Charges LIBMAY22	11-7-601-21.00 Library-Postage	6.38	225291	06/30/22
BUSINESSC	06/17/22	COMMERCIAL CARD SERVICES 5/13-6/5/22 Charges LIBMAY22	11-7-601-21.00 Library-Postage	11.49	225291	06/30/22
BUSINESSC	06/17/22	COMMERCIAL CARD SERVICES 5/13-6/5/22 Charges LIBMAY22	11-7-302-38.10 Parks & Recreation Commis	97.08	225291	06/30/22
BUSINESSC	06/17/22	COMMERCIAL CARD SERVICES 5/13-6/5/22 Charges LIBMAY22	11-7-601-29.20 Library-Travel Reim/Lib ex	82.95	225291	06/30/22
BUSINESSC	06/21/22	COMMERCIAL CARD SERVICES Creditcard 5/11-5/24/22 WWVFD 6/22	11-7-207-20.00 Supplies	1008.39	225291	06/30/22
BUSINESSC	06/21/22	COMMERCIAL CARD SERVICES Creditcard 5/11-5/24/22 WWVFD 6/22	11-7-207-51.00 WWVFD Fuel	100.00	225291	06/30/22
BUSINESSC	06/21/22	COMMERCIAL CARD SERVICES Creditcard 5/11-5/24/22 WWVFD 6/22	11-7-207-20.00 Supplies	103.39	225291	06/30/22
AFLAC	06/02/22	AFLAC Payroll Transfer PR-06/02/22	11-2-011-10.00 AFLAC	54.63	225292	06/30/22
AFLAC	06/09/22	AFLAC Payroll Transfer PR-06/09/22	11-2-011-10.00 AFLAC	54.63	225292	06/30/22
AFLAC	06/16/22	AFLAC Payroll Transfer PR-06/16/22	11-2-011-10.00 AFLAC	54.63	225292	06/30/22
AFLAC	06/23/22	AFLAC Payroll Transfer PR-06/23/22	11-2-011-10.00 AFLAC	54.63	225292	06/30/22
AFLAC	06/30/22	AFLAC Payroll Transfer PR-06/30/22	11-2-011-10.00 AFLAC	54.63	225292	06/30/22
AFD#2 WAT	06/23/22	ASCUTNEY FIRE DISTRICT#2 Water payment Apr-Jun22 LIBAPR-JUN22	11-7-601-34.00 Library-Water	55.44	225293	06/30/22
AFD#2 WAT	06/23/22	ASCUTNEY FIRE DISTRICT#2 Water pymt Apr-June 22 MMHAPR-JUN22	11-7-301-34.00 Water	112.62	225293	06/30/22
COLONI	06/02/22	COLONIAL LIFE Payroll Transfer PR-06/02/22	11-2-011-14.10 Insurance Prem Liability	6.69	225295	06/30/22
COLONI	06/09/22	COLONIAL LIFE Payroll Transfer PR-06/09/22	11-2-011-14.10 Insurance Prem Liability	6.69	225295	06/30/22
COLONI	06/16/22	COLONIAL LIFE Payroll Transfer PR-06/16/22	11-2-011-14.10 Insurance Prem Liability	6.69	225295	06/30/22
COLONI	06/23/22	COLONIAL LIFE Payroll Transfer PR-06/23/22	11-2-011-14.10 Insurance Prem Liability	6.69	225295	06/30/22

Vendor	Invoice Date	Invoice Description	Account	Amount Paid	Check Number	Check Date
COLONI	06/30/22	Payroll Transfer	11-2-011-14.10	6.69	225295	06/30/22
		PR-06/30/22	Insurance Prem Liability			
COMCAST	06/24/22	6/15/22-07/14/22 phone	11-7-101-31.00	345.95	225297	06/30/22
		JUN15-JUL14	GF-Telephone			
COMCAST	06/24/22	6/15/22-07/14/22 phone	11-7-601-31.00	77.58	225297	06/30/22
		JUN15-JUL14	Library-Telephone			
COTTSYSSTE	06/21/22	July 2022	11-1-030-00.00	345.00	225298	06/30/22
		147635	Prepaid Expenses & Insr			
FORDCL	06/17/22	Brake pad Car 2	11-7-201-52.00	742.78	225300	06/30/22
		54700	Repairs and Supplies			
GMP	06/21/22	5/15-6/14 #18968200008	11-7-206-30.10	180.53	225302	06/30/22
		AVFDJUNE22	Electricity			
GMP	06/21/22	5/16-6/15 31168200009	11-7-301-30.00	235.78	225302	06/30/22
		MMHJUNE22	Electricity & Gas			
INGRA	06/17/22	Books	11-7-601-78.00	16.64	225304	06/30/22
		59829079	Library-Media			
INGRA	06/17/22	Books	11-7-601-78.00	26.32	225304	06/30/22
		59883317	Library-Media			
FARNSWORT	06/01/22	Cleaning 6/23/22	11-7-301-40.00	100.00	225305	06/30/22
		130	Custodial Services			
FARNSWORT	06/01/22	Cleaning 6/23/22	11-7-601-40.00	50.00	225305	06/30/22
		131	Custodial Services			
FARNSWORT	06/01/22	Cleaning 6/30/22	11-7-301-40.00	100.00	225305	06/30/22
		132	Custodial Services			
FARNSWORT	06/01/22	Cleaning 6/30/22	11-7-601-40.00	50.00	225305	06/30/22
		133	Custodial Services			
IRVINGOIL	06/27/22	Library 66.1 gal heatoil	11-7-601-32.00	339.96	225306	06/30/22
		147686	Library-Heating & Fuel			
MADISON	06/21/22	July'22 Premiums	11-7-103-14.10	23.39	225310	06/30/22
		JULY2022	TC-Insurance Benefits			
MADISON	06/21/22	July'22 Premiums	11-7-201-14.10	101.83	225310	06/30/22
		JULY2022	Police-Insurance Benefits			
MADISON	06/21/22	July'22 Premiums	11-7-601-14.10	130.44	225310	06/30/22
		JULY2022	Library-Insurance Benft			
MADISON	06/21/22	July'22 Premiums	11-7-201-14.10	30.81	225310	06/30/22
		JULY2022	Police-Insurance Benefits			
MADISON	06/21/22	July'22 Premiums	11-7-101-14.10	19.72	225310	06/30/22
		JULY2022	GF-Insurance Benefits			
MADISON	06/21/22	July'22 Premiums	11-7-101-14.10	40.50	225310	06/30/22
		JULY2022	GF-Insurance Benefits			
MADISON	06/21/22	July'22 Premiums	11-7-103-14.10	17.54	225310	06/30/22
		JULY2022	TC-Insurance Benefits			
MADISON	06/21/22	July'22 Premiums	11-7-101-14.10	29.64	225310	06/30/22
		JULY2022	GF-Insurance Benefits			
SWCRP	06/23/22	FY23 Annual assessment	11-1-030-00.00	3694.60	225311	06/30/22
		DUES # 8	Prepaid Expenses & Insr			
MVP	06/21/22	July 22 Premiums	11-7-601-14.10	733.54	225312	06/30/22
		JULY22PREM	Library-Insurance Benft			
MVP	06/21/22	July 22 Premiums	11-7-101-14.10	587.59	225312	06/30/22
		JULY22PREM	GF-Insurance Benefits			

Vendor		Invoice Date	Invoice Description Invoice Number	Account	Amount Paid	Check Number	Check Date
MVP	MVP HEALTH CARE	06/21/22	July 22 Premiums JULY22PREM	11-7-101-14.10 GF-Insurance Benefits	1175.17	225312	06/30/22
MVP	MVP HEALTH CARE	06/21/22	July 22 Premiums JULY22PREM	11-7-201-14.10 Police-Insurance Benefits	1134.04	225312	06/30/22
MVP	MVP HEALTH CARE	06/21/22	July 22 Premiums JULY22PREM	11-7-201-14.10 Police-Insurance Benefits	1651.11	225312	06/30/22
MVP	MVP HEALTH CARE	06/21/22	July 22 Premiums JULY22PREM	11-2-011-14.10 Insurance Prem Liability	1928.86	225312	06/30/22
N DELT	NORTHEAST DELTA DENTAL	06/21/22	July 22 Premiums JULY2022	11-7-101-14.10 GF-Insurance Benefits	35.98	225313	06/30/22
N DELT	NORTHEAST DELTA DENTAL	06/21/22	July 22 Premiums JULY2022	11-7-103-14.10 TC-Insurance Benefits	68.55	225313	06/30/22
N DELT	NORTHEAST DELTA DENTAL	06/21/22	July 22 Premiums JULY2022	11-7-101-14.10 GF-Insurance Benefits	68.55	225313	06/30/22
N DELT	NORTHEAST DELTA DENTAL	06/21/22	July 22 Premiums JULY2022	11-7-201-14.10 Police-Insurance Benefits	68.55	225313	06/30/22
N DELT	NORTHEAST DELTA DENTAL	06/21/22	July 22 Premiums JULY2022	11-7-101-14.10 GF-Insurance Benefits	129.44	225313	06/30/22
N DELT	NORTHEAST DELTA DENTAL	06/21/22	July 22 Premiums JULY2022	11-7-201-14.10 Police-Insurance Benefits	129.44	225313	06/30/22
N DELT	NORTHEAST DELTA DENTAL	06/21/22	July 22 Premiums JULY2022	11-7-601-14.10 Library-Insurance Benft	129.44	225313	06/30/22
OREILLY	O'REILLY AUTO PARTS	06/17/22	Supply police 5683-320168	11-7-201-52.00 Repairs and Supplies	44.97	225314	06/30/22
VTAGHUMAN	OFFICE OF CHILD SUPPORT	06/23/22	Payroll Transfer PR-06/23/22	11-2-011-07.00 Garnishments	327.84	225315	06/30/22
VTAGHUMAN	OFFICE OF CHILD SUPPORT	06/30/22	Payroll Transfer PR-06/30/22	11-2-011-07.00 Garnishments	327.84	225315	06/30/22
ROCELE	ROCKINGHAM ELECTRICAL SUP	06/21/22	Lev 5369-C blk conn-n5-20 S3550209.001	11-7-206-60.00 Maintenance & Repairs	11.90	225316	06/30/22
SULLIVANC	SULLIVAN, CATHY	06/17/22	June'22 animal control JUNE2022	11-7-202-10.10 Animal Control Salary	500.00	225319	06/30/22
TERR	TERRILL, SUSANNE	06/24/22	postage and condiments REIMBJUN22	11-7-101-29.20 GF-Travel/Mileage	6.20	225320	06/30/22
TJ PROPER	TJ PROPERTY MANAGEMENT LL	06/29/22	Annual mowing Trimming 6107	11-7-302-38.85 Town Parks	70.00	225321	06/30/22
VLCT MUNI	VLCT	06/21/22	FY23 Dues RGD2023-0220	11-1-030-00.00 Prepaid Expenses & Insr	4679.00	225325	06/30/22
VMERS DB	VMERS DB.	06/02/22	Payroll Transfer PR-06/02/22	11-2-011-05.00 Retirement	2610.40	225326	06/30/22
VMERS DB	VMERS DB.	06/09/22	Payroll Transfer PR-06/09/22	11-2-011-05.00 Retirement	2240.22	225326	06/30/22
VMERS DB	VMERS DB.	06/16/22	Payroll Transfer PR-06/16/22	11-2-011-05.00 Retirement	2389.02	225326	06/30/22
VMERS DB	VMERS DB.	06/23/22	Payroll Transfer PR-06/23/22	11-2-011-05.00 Retirement	2400.26	225326	06/30/22
VMERS DB	VMERS DB.	06/30/22	Payroll Transfer PR-06/30/22	11-2-011-05.00 Retirement	2324.23	225326	06/30/22
STAPLES	STAPLES CREDIT PLAN	06/17/22	Office Supplies 3080660231	11-7-301-20.00 Custodial Supplies	35.98	225331	06/30/22

Vendor	Invoice Date	Invoice Description	Account	Amount Paid	Check Number	Check Date
STAPLES	06/17/22	STAPLES CREDIT PLAN Office Supplies 3080660231	11-7-101-20.00 GF-Office Supplies	24.49	225331	06/30/22
STAPLES	06/21/22	STAPLES CREDIT PLAN DVD Police 3083429701	11-7-201-20.00 Police-Office Supplies	28.99	225331	06/30/22
STAPLES	06/21/22	STAPLES CREDIT PLAN Office Supplies 3083585581	11-7-101-20.00 GF-Office Supplies	53.48	225331	06/30/22
STAPLES	06/21/22	STAPLES CREDIT PLAN Downstairs supplies 3084274371	11-7-301-20.00 Custodial Supplies	9.68	225331	06/30/22
DANIELSCO	06/30/22	Daniels Contruction, Inc State inspection & tires 61042	11-7-206-60.10 Vehicle Maintenance	675.00	225332	06/30/22
COMCASTBU	06/17/22	COMCAST INTERNET Acct8773501440004484 AVFD JUNE 22	11-7-206-31.00 Telephone & Internet	79.79	225333	06/30/22
ASVFD	06/29/22	ASCUTNEY VOL. FIRE DEPT. Kathy Girard Cadet Academ REIMB42922	11-7-206-27.00 Training	300.00	225334	06/30/22
COMPOTRAV	06/24/22	COMPO, TRAVIS Water and Juice for WWVFD REIMB 6-8-22	11-7-207-20.00 Supplies	115.28	225336	06/30/22
DAUPHINT	06/24/22	DAUPHIN TRACY Reimburse for WWVFD REIMBJUNE	11-7-207-20.00 Supplies	29.14	225338	06/30/22
DAUPHINT	06/24/22	DAUPHIN TRACY Reimburse for WWVFD REIMBJUNE	11-7-207-20.00 Supplies	55.72	225338	06/30/22
DONKER	06/24/22	DONKER BRITTANY RN to EMT Course/Training REIMBJUNE22	11-7-207-27.00 Training	750.00	225339	06/30/22
WWVFD	06/24/22	WEST WEATHERSF. VOL. FIRE Hose testing 2022 05242022	11-7-207-30.01 Hose Testing	1500.00	225343	06/30/22
WWVFD	06/24/22	WEST WEATHERSF. VOL. FIRE June Reimbursement JUNE22REIM	11-7-207-60.00 Maintenance & Repair	1560.00	225343	06/30/22
ROTARY	06/30/22	WINDSOR ROTARY CLUB Membership Dues 21-22DUES	11-7-101-27.00 GF-Tuition and Dues	140.00	225344	06/30/22
GULNIK	06/30/22	GULNICK, BRANDON 6/17-6/30 Mileage MILES6/17-30	11-7-101-29.20 GF-Travel/Mileage	31.01	225345	06/30/22
TJ PROPER	06/30/22	TJ PROPERTY MANAGEMENT LL mowing/trimming June22 6121	11-7-301-60.10 Building Maintenance	225.00	225346	06/30/22
TJ PROPER	06/30/22	TJ PROPERTY MANAGEMENT LL mowing/trimming June22 6121	11-7-302-38.85 Town Parks	140.00	225346	06/30/22
TJ PROPER	06/30/22	TJ PROPERTY MANAGEMENT LL mowing/trimming June22 6121	11-7-601-62.10 Library-Building Maint.	175.00	225346	06/30/22
TJ PROPER	06/30/22	TJ PROPERTY MANAGEMENT LL mowing/trimming June22 6121	11-7-302-38.85 Town Parks	150.00	225346	06/30/22
TJ PROPER	06/30/22	TJ PROPERTY MANAGEMENT LL mowing/trimming June22 6121	11-7-302-38.85 Town Parks	350.00	225346	06/30/22
TJ PROPER	06/30/22	TJ PROPERTY MANAGEMENT LL mowing/trimming June22 6121	11-7-302-38.85 Town Parks	250.00	225346	06/30/22
TJ PROPER	06/30/22	TJ PROPERTY MANAGEMENT LL mowing/trimming June22 6121	11-7-302-39.00 1879 School house Maint	100.00	225346	06/30/22
TDS	06/30/22	TDS TELECOM 06/04-07/03/2022 2635146JUN22	11-7-302-39.00 1879 School house Maint	41.34	225347	06/30/22
AMAZONCR	06/24/22	AMAZON Supplies downstairs 459797786758	11-7-301-60.10 Building Maintenance	89.94	225353	06/30/22
AMAZONCR	06/17/22	AMAZON Fishing Theme - Programs 46774738897	11-7-601-38.00 Library-Library Programs	21.18	225353	06/30/22

06/30/22
03:13 pm

Town of Weathersfield Accounts Payable
Check Warrant Report # 19547 Current Prior Next FY Invoices For Fund (General Fund)
For Check Acct 1 (General Fund) All check #s 06/30/22 To 06/30/22

Page 5 of 5
payroll

Vendor	Invoice Date	Invoice Description Invoice Number	Account	Amount Paid	Check Number	Check Date
AMAZONCR	AMAZON	06/17/22 books 468867764834	11-7-601-78.00 Library-Media	36.26	225353	06/30/22
AMAZONCR	AMAZON	06/24/22 timecard ink 696933873537	11-7-101-20.00 GF-Office Supplies	8.69	225353	06/30/22
AMAZONCR	AMAZON	06/24/22 Supplies downstairs 783396334466	11-7-301-60.10 Building Maintenance	38.98	225353	06/30/22
AMAZONCR	AMAZON	06/17/22 Fishing Theme - Programs 986886577859	11-7-601-38.00 Library-Library Programs	21.18	225353	06/30/22
BERGERON	BERGERON PROTECTIVE CLOTH	06/30/22 Hose 232322	11-7-206-60.00 Maintenance & Repairs	477.48	225356	06/30/22
Report Total				42373.47		

Vendor	Invoice Date	Invoice Description	Account	Amount Paid	Check Number	Check Date
BUSINESSC	06/21/22	COMMERCIAL CARD SERVICES 5/12-6/5/22 creditcard	12-7-101-27.00	500.00	225291	06/30/22
		ADMINMAY22	Training and Conferences			
BUSINESSC	06/17/22	COMMERCIAL CARD SERVICES 5/12-5/29/22 charges	12-7-101-20.00	0.99	225291	06/30/22
		HWAYMAY22	Office Supplies			
BUSINESSC	06/17/22	COMMERCIAL CARD SERVICES 5/12-5/29/22 charges	12-7-101-35.10	14.99	225291	06/30/22
		HWAYMAY22	Security System Maint			
BUSINESSC	06/17/22	COMMERCIAL CARD SERVICES 5/12-5/29/22 charges	12-7-101-52.00	31.79	225291	06/30/22
		HWAYMAY22	Repairs & Supplies			
BUSINESSC	06/17/22	COMMERCIAL CARD SERVICES 5/12-5/29/22 charges	12-7-101-20.00	5.29	225291	06/30/22
		HWAYMAY22	Office Supplies			
BIBENS	06/29/22	BIBENS HOME CENTER INC. Pole Pruner	12-7-101-53.00	755.98	225294	06/30/22
		505511/1	Equipment			
COMCAST	06/24/22	COMCAST PHONE 6/15/22-07/14/22 phone	12-7-101-31.00	65.22	225297	06/30/22
		JUN15-JUL14	Wireless/Pager Service			
CVC	06/27/22	CVC PAGING Mobil Service	12-7-101-52.00	420.00	225299	06/30/22
		21220607	Repairs & Supplies			
GORMAN	06/29/22	GORMAN GROUP, LLC 4605 gal summer calcium	12-7-101-58.30	4743.15	225301	06/30/22
		11012277	Chloride			
LANE-BALL	06/29/22	LANE ENTERPRISES INC. CULVERTS	12-7-101-58.60	4928.00	225308	06/30/22
		545508	Culverts			
LAWSON	06/21/22	LAWSON PRODUCTS, INC Sales Order #8439440	12-7-101-52.00	113.60	225309	06/30/22
		9309656029	Repairs & Supplies			
MADISON	06/21/22	MADISON NATIONAL LIFE INS July'22 Premiums	12-7-101-14.10	25.61	225310	06/30/22
		JULY2022	HWY-Insurance Benefits			
MADISON	06/21/22	MADISON NATIONAL LIFE INS July'22 Premiums	12-7-101-14.10	24.00	225310	06/30/22
		JULY2022	HWY-Insurance Benefits			
MADISON	06/21/22	MADISON NATIONAL LIFE INS July'22 Premiums	12-7-101-14.10	27.17	225310	06/30/22
		JULY2022	HWY-Insurance Benefits			
MADISON	06/21/22	MADISON NATIONAL LIFE INS July'22 Premiums	12-7-101-14.10	22.56	225310	06/30/22
		JULY2022	HWY-Insurance Benefits			
MADISON	06/21/22	MADISON NATIONAL LIFE INS July'22 Premiums	12-7-101-14.10	28.45	225310	06/30/22
		JULY2022	HWY-Insurance Benefits			
MADISON	06/21/22	MADISON NATIONAL LIFE INS July'22 Premiums	12-7-101-14.10	25.61	225310	06/30/22
		JULY2022	HWY-Insurance Benefits			
MADISON	06/21/22	MADISON NATIONAL LIFE INS July'22 Premiums	12-7-101-14.10	33.47	225310	06/30/22
		JULY2022	HWY-Insurance Benefits			
MVP	06/21/22	MVP HEALTH CARE July 22 Premiums	12-7-101-14.10	1175.17	225312	06/30/22
		JULY22PREM	HWY-Insurance Benefits			
MVP	06/21/22	MVP HEALTH CARE July 22 Premiums	12-7-101-14.10	587.59	225312	06/30/22
		JULY22PREM	HWY-Insurance Benefits			
MVP	06/21/22	MVP HEALTH CARE July 22 Premiums	12-7-101-14.10	587.59	225312	06/30/22
		JULY22PREM	HWY-Insurance Benefits			
MVP	06/21/22	MVP HEALTH CARE July 22 Premiums	12-7-101-14.10	1651.11	225312	06/30/22
		JULY22PREM	HWY-Insurance Benefits			
MVP	06/21/22	MVP HEALTH CARE July 22 Premiums	12-7-101-14.10	1651.11	225312	06/30/22
		JULY22PREM	HWY-Insurance Benefits			
MVP	06/21/22	MVP HEALTH CARE July 22 Premiums	12-7-101-14.10	1175.17	225312	06/30/22
		JULY22PREM	HWY-Insurance Benefits			
N DELT	06/21/22	NORTHEAST DELTA DENTAL July 22 Premiums	12-7-101-14.10	35.98	225313	06/30/22
		JULY2022	HWY-Insurance Benefits			

06/30/22
03:13 pm

Town of Weathersfield Accounts Payable
Check Warrant Report # 19547 Current Prior Next FY Invoices For Fund (Highway Fund)
For Check Acct 1 (General Fund) All check #s 06/30/22 To 06/30/22

Page 2 of 3
payroll

Vendor	Invoice Date	Invoice Description	Invoice Number	Account	Amount Paid	Check Number	Check Date
N DELT	06/21/22	July 22 Premiums	JULY2022	12-7-101-14.10 HWY-Insurance Benefits	129.44	225313	06/30/22
N DELT	06/21/22	July 22 Premiums	JULY2022	12-7-101-14.10 HWY-Insurance Benefits	68.55	225313	06/30/22
N DELT	06/21/22	July 22 Premiums	JULY2022	12-7-101-14.10 HWY-Insurance Benefits	68.55	225313	06/30/22
N DELT	06/21/22	July 22 Premiums	JULY2022	12-7-101-14.10 HWY-Insurance Benefits	68.55	225313	06/30/22
N DELT	06/21/22	July 22 Premiums	JULY2022	12-7-101-14.10 HWY-Insurance Benefits	129.44	225313	06/30/22
STPIERRE	06/21/22	1" gravel blend	1011613	12-7-101-58.26 Gravel Purchase	8367.67	225318	06/30/22
TERR	06/24/22	postage and condiments	REIMBJUN22	12-7-101-27.00 Training and Conferences	45.77	225320	06/30/22
UIST	06/17/22	6/17/22 uniforms	1070139373	12-7-101-15.20 HWY-Uniforms & Cleaning	121.78	225322	06/30/22
UIST	06/27/22	6/24/22 uniforms	1070141242	12-7-101-15.20 HWY-Uniforms & Cleaning	121.78	225322	06/30/22
VALLEYNEW	06/29/22	RFP Paving	655655	12-7-101-23.50 Highway Advertising	44.20	225323	06/30/22
VIKECIVES	06/24/22	Parts Cable	4516833	12-7-101-52.00 Repairs & Supplies	308.45	225328	06/30/22
BIBENS	06/30/22	Hwy batteries	505573/1	12-7-101-52.00 Repairs & Supplies	17.99	225335	06/30/22
CVC	06/30/22	Radio installation	10385729	12-7-101-52.00 Repairs & Supplies	366.42	225337	06/30/22
MCMASTER	06/30/22	housing for pole, gauge	80646039	12-7-101-52.00 Repairs & Supplies	46.46	225340	06/30/22
PIKE	06/30/22	Center & Res Paving	44142	12-7-101-57.15 Reconstruct/Pave Class 2	50000.00	225341	06/30/22
VALLEYNEW	06/30/22	RFP Quarry Road	656812	12-7-101-23.50 Highway Advertising	45.90	225342	06/30/22
AMAZONCR	06/24/22	timecard ink	437785744698	12-7-101-20.00 Office Supplies	8.69	225353	06/30/22
AMAZONCR	06/30/22	welder adapter	449683536459	12-7-101-52.00 Repairs & Supplies	62.99	225353	06/30/22
AMAZONCR	06/30/22	Fishing sled	454539639869	12-7-101-52.00 Repairs & Supplies	59.99	225353	06/30/22
AMAZONCR	06/30/22	Absorbent pads	467878984656	12-7-101-52.00 Repairs & Supplies	92.00	225353	06/30/22
AMAZONCR	06/21/22	Supplies	468885343888	12-7-101-52.00 Repairs & Supplies	26.98	225353	06/30/22
AMAZONCR	06/30/22	Supplies	544868364793	12-7-101-20.00 Office Supplies	147.15	225353	06/30/22
AMAZONCR	06/30/22	swivel joint	773378368379	12-7-101-52.00 Repairs & Supplies	54.96	225353	06/30/22
AMAZONCR	06/30/22	Sled camo cover	834355939966	12-7-101-52.00 Repairs & Supplies	39.02	225353	06/30/22
AMAZONCR	06/30/22	groove fittings	846787757666	12-7-101-52.00 Repairs & Supplies	19.11	225353	06/30/22

06/30/22
03:13 pm

Town of Weathersfield Accounts Payable
Check Warrant Report # 19547 Current Prior Next FY Invoices For Fund (Highway Fund)
For Check Acct 1 (General Fund) All check #s 06/30/22 To 06/30/22

Page 3 of 3
payroll

Vendor	Invoice Date	Invoice Description Invoice Number	Account	Amount Paid	Check Number	Check Date
AMAZONCR	AMAZON	06/30/22 casters 874563578637	12-7-101-52.00 Repairs & Supplies	36.86	225353	06/30/22
AMAZONCR	AMAZON	06/21/22 Supplies 943679663438	12-7-101-24.00 Equipment	58.36	225353	06/30/22
AMAZONCR	AMAZON	06/30/22 groove fittings 953545768497	12-7-101-52.00 Repairs & Supplies	28.13	225353	06/30/22
AMAZONCR	AMAZON	06/24/22 Supplies 959468787599	12-7-101-53.50 Safety Equipment	76.16	225353	06/30/22
AMAZONCR	AMAZON	06/30/22 emilminizer hwy 968657864999	12-7-101-52.00 Repairs & Supplies	229.00	225353	06/30/22
AMAZONCR	AMAZON	06/30/22 vise hwy 997678643567	12-7-101-52.00 Repairs & Supplies	145.99	225353	06/30/22
Report Total				79665.94		

06/30/22
03:13 pm

Town of Weathersfield Accounts Payable
Check Warrant Report # 19547 Current Prior Next FY Invoices For Fund (Special Revenue)
For Check Acct 1 (General Fund) All check #s 06/30/22 To 06/30/22

Page 1 of 1
payroll

Vendor	Invoice Date	Invoice Description Invoice Number	Account	Amount Paid	Check Number	Check Date
JARVIS	06/29/22	Ditching Melody Lane 3874	15-7-209-11.22 Melody Lane Ditching	7322.50	225307	06/30/22
LANE-BALL	06/27/22	LANE ENTERPRISES INC. CULVERTS GIA Old Bow 545507	15-7-209-19.22 Old Bow Culverts	3371.80	225308	06/30/22
AMAZONCR	06/21/22	AMAZON Pacif Grant FY22 559786973796	15-7-208-01.00 GF-VLCT-PACIF Grant	395.98	225353	06/30/22
AMAZONCR	06/30/22	AMAZON Pacif Grant FY22 586334935693	15-7-208-01.00 GF-VLCT-PACIF Grant	600.22	225353	06/30/22
AMAZONCR	06/21/22	AMAZON Pacif Grant FY22 734683547784	15-7-208-01.00 GF-VLCT-PACIF Grant	197.99	225353	06/30/22
AMAZONCR	06/30/22	AMAZON Pacif Grant FY22 768855744463	15-7-208-01.00 GF-VLCT-PACIF Grant	567.85	225353	06/30/22
AMAZONCR	06/24/22	AMAZON Pacif Grant FY22 864859844988	15-7-208-01.00 GF-VLCT-PACIF Grant	479.99	225353	06/30/22
AMAZONCR	06/24/22	AMAZON Pacif Grant FY22 974689379889	15-7-208-01.00 GF-VLCT-PACIF Grant	323.99	225353	06/30/22
Report Total				13260.32		

06/30/22

Town of Weathersfield Accounts Payable

03:13 pm

Check Warrant Report # 19547 Current Prior Next FY Invoices For Fund (Solid Waste)

payroll

For Check Acct 1(General Fund) All check #s 06/30/22 To 06/30/22

Vendor		Invoice Date	Invoice Description Invoice Number	Account	Amount Paid	Check Number	Check Date
COMCAST	COMCAST PHONE	06/24/22	6/15/22-07/14/22 phone JUN15-JUL14	21-7-101-31.00 Telephone	110.10	225297	06/30/22
MADISON	MADISON NATIONAL LIFE INS	06/21/22	July'22 Premiums JULY2022	21-7-101-14.10 Insurance Benefits	15.95	225310	06/30/22
N DELT	NORTHEAST DELTA DENTAL	06/21/22	July 22 Premiums JULY2022	21-7-101-14.10 Insurance Benefits	35.98	225313	06/30/22
VALLEYNEW	VALLEY NEWS	06/29/22	RFP Trash Compactor 655654	21-7-101-23.50 Advertising	57.80	225323	06/30/22
Report Total					----- 219.83 =====		

06/30/22

Town of Weathersfield Accounts Payable

03:13 pm

Check Warrant Report # 19547 Current Prior Next FY Invoices For Fund (Reserves)
For Check Acct 1 (General Fund) All check #s 06/30/22 To 06/30/22

payroll

Vendor	Invoice Date	Invoice Description Invoice Number	Account	Amount Paid	Check Number	Check Date
COTTSYSTEMS COTT SYSTEMS	06/21/22	Label printer 147789	41-7-440-07.15 Expense - TC Comp.	1090.00	225298	06/30/22
HENDERRIK HENDERSON, RIKA	06/28/22	plants memorial garden VETGARFLOWER	41-7-420-07.15 Expense - Vet. Mem.	25.40	225303	06/30/22
PIKE PIKE INDUSTRIES, INC.	06/30/22	Center & Res Paving 44142	41-7-405-07.15 Expense - Hwy Cap.	98311.39	225341	06/30/22
Report Total				99426.79		

06/30/22
03:16 pm

Town of Weathersfield Payroll
Check Warrant Report #
Check date 06/23/22 to 06/23/22 Departments 111 to 111

Page 1 of 1
payroll

Employee Number	Employee Name		Check Number	Check Date	Net Amount	Elec Amount
BALLAM	BALLAM, MARION J.	E	15168	06/23/22	0.00	508.69
DANGOF	DANGO, FLORA ANN	E	15171	06/23/22	0.00	772.67
DANIELSWI	DANIELS, WILLIAM J.	E	15172	06/23/22	0.00	1649.65
ESTYJOSH	ESTY, JOSHUA W.	E	15174	06/23/22	0.00	197.89
GRAHAMJ	GRAHAM, JOHN J.	E	15175	06/23/22	0.00	371.18
GULNICKB	GULNICK, BRANDON W.	E	15176	06/23/22	0.00	1103.14
GUMBART	GUMBART, RYAN C.	E	15177	06/23/22	0.00	358.52
HIERS	HIER, STEVE A.	E	15178	06/23/22	0.00	233.07
PRINCE	PRINCE, RYAN C.	E	15183	06/23/22	0.00	1300.68
SAVAGE	SAVAGE, OLIVIA I.	E	15185	06/23/22	0.00	460.06
SMITH	SMITH, STEVEN		48106	06/23/22	187.52	0.00
TERRILL	TERRILL, SUSANNE	E	15187	06/23/22	0.00	864.68
THOMASB	THOMAS, BARBARA A.	E	15188	06/23/22	0.00	150.35
					-----	-----
					187.52	7970.58
					=====	=====

***8,158.10

06/30/22
03:16 pm

Town of Weathersfield Payroll
Check Warrant Report #
Check date 06/23/22 to 06/23/22 Departments 121 to 121

Page 1 of 1
payroll

Employee Number	Employee Name	Check Number	Check Date	Net Amount	Elec Amount
BEARSED	BEARSE, DAVID E.	E 15169	06/23/22	0.00	631.83
ESTYJO	ESTY, JOHN W.	E 15173	06/23/22	0.00	774.61
HUNTDON	HUNTLEY, DONALD A.	E 15179	06/23/22	0.00	626.63
LONGTIN	LONGTIN, ALEXANDER J.	E 15180	06/23/22	0.00	439.54
MOORER	MOORE, RAY A.	E 15182	06/23/22	0.00	695.57
STAPLETON	STAPLETON, RAY E.	E 15186	06/23/22	0.00	802.58
				-----	-----
				0.00	3970.76
				=====	=====

***3,970.76

06/30/22
03:16 pm

Town of Weathersfield Payroll
Check Warrant Report #
Check date 06/23/22 to 06/23/22 Departments 131 to 131

Page 1 of 1
payroll

Employee Number	Employee Name		Check Number	Check Date	Net Amount	Elec Amount
COLEMAN	COLEMAN, GLENNA J.	E	15170	06/23/22	0.00	141.81
RICHARDMA	RICHARDSON, MARK P.	E	15184	06/23/22	0.00	708.58
TOPOLSKI	TOPOLSKI, JUDITH A.	E	15190	06/23/22	0.00	224.75
					-----	-----
					0.00	1075.14
					=====	=====

***1,075.14

06/30/22
03:16 pm

Town of Weathersfield Payroll
Check Warrant Report #
Check date 06/23/22 to 06/23/22 Departments 211 to 211

Page 1 of 1
payroll

Employee Number	Employee Name	Check Number	Check Date	Net Amount	Elec Amount
DENNETTSH	DENNETT, SHAWN M.	48105	06/23/22	67.34	0.00
MERICLE J	MERICLE, JAMES S.	E 15181	06/23/22	0.00	349.14
WATERST	WATERS, TYLER M.	E 15191	06/23/22	0.00	524.41
				-----	-----
				67.34	873.55
				=====	=====

*****940.89

06/30/22
03:15 pm

Town of Weathersfield Payroll
Check Warrant Report #
Check date 06/30/22 to 06/30/22 Departments 111 to 111

Page 1 of 1
payroll

Employee Number	Employee Name		Check Number	Check Date	Net Amount	Elec Amount
BALLAM	BALLAM, MARION J.	E	15192	06/30/22	0.00	437.47
BATES	BATES, RODERICK G.		48108	06/30/22	153.92	0.00
DANGOF	DANGO, FLORA ANN	E	15195	06/30/22	0.00	772.67
DANIELSWI	DANIELS, WILLIAM J.	E	15196	06/30/22	0.00	1790.31
GRAHAMJ	GRAHAM, JOHN J.	E	15198	06/30/22	0.00	186.34
GULNICKB	GULNICK, BRANDON W.	E	15199	06/30/22	0.00	1103.14
GUMBART	GUMBART, RYAN C.	E	15200	06/30/22	0.00	358.52
HIERS	HIER, STEVE A.	E	15201	06/30/22	0.00	233.07
HODGDON	HODGDON, COLBY G.		48110	06/30/22	525.99	0.00
PRINCE	PRINCE, RYAN C.	E	15206	06/30/22	0.00	1038.20
SAVAGE	SAVAGE, OLIVIA I.	E	15208	06/30/22	0.00	399.04
SAVAGE	SAVAGE, OLIVIA I.	E	15209	06/30/22	0.00	72.73
Total of 2 items for SAVAGE					0.00	471.77
SMITH	SMITH, STEVEN		48111	06/30/22	187.52	0.00
TERRILL	TERRILL, SUSANNE	E	15211	06/30/22	0.00	864.68
THOMASB	THOMAS, BARBARA A.	E	15212	06/30/22	0.00	273.68
					867.43	7529.85
					=====	=====

***8,397.28

06/30/22
03:15 pm

Town of Weathersfield Payroll
Check Warrant Report #
Check date 06/30/22 to 06/30/22 Departments 121 to 121

Page 1 of 1
payroll

Employee Number	Employee Name	Check Number	Check Date	Net Amount	Elec Amount
BEARSED	BEARSE, DAVID E.	E 15193	06/30/22	0.00	610.34
ESTYJO	ESTY, JOHN W.	E 15197	06/30/22	0.00	773.57
HUNTDON	HUNTLEY, DONALD A.	E 15202	06/30/22	0.00	611.57
LONGTIN	LONGTIN, ALEXANDER J.	E 15203	06/30/22	0.00	432.14
MOORER	MOORE, RAY A.	E 15205	06/30/22	0.00	686.24
STAPLETON	STAPLETON, RAY E.	E 15210	06/30/22	0.00	802.58
				-----	-----
				0.00	3916.44
				=====	=====

***3,916.44

06/30/22
03:15 pm

Town of Weathersfield Payroll
Check Warrant Report #
Check date 06/30/22 to 06/30/22 Departments 131 to 131

Page 1 of 1
payroll

Employee Number	Employee Name	Check Number	Check Date	Net Amount	Elec Amount
COLEMAN	COLEMAN, GLENNA J.	E 15194	06/30/22	0.00	129.56
RICHARDMA	RICHARDSON, MARK P.	E 15207	06/30/22	0.00	708.58
TOPOLSKI	TOPOLSKI, JUDITH A.	E 15214	06/30/22	0.00	157.40
				-----	-----
				0.00	995.54
				=====	=====

*****995.54

06/30/22
03:15 pm

Town of Weathersfield Payroll
Check Warrant Report #
Check date 06/30/22 to 06/30/22 Departments 211 to 211

Page 1 of 1
payroll

Employee Number	Employee Name	Check Number	Check Date	Net Amount	Elec Amount
BARTON	BARTON, JEREMY F.	48107	06/30/22	69.54	0.00
MERICLE J	MERICLE, JAMES S.	E 15204	06/30/22	0.00	294.04
WATERST	WATERS, TYLER M.	E 15215	06/30/22	0.00	496.03
				-----	-----
				69.54	790.07
				=====	=====

*****859.61